

NORMAL HEADROOM, CURVED TRACK; 2 PART SINGLE
Hoist type:
SX4021...N0

US-60Hz

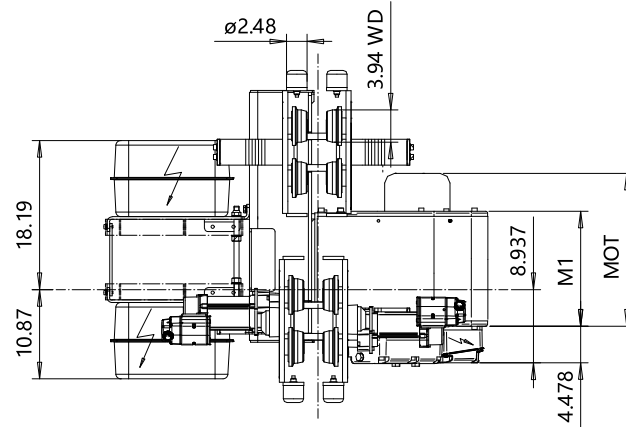
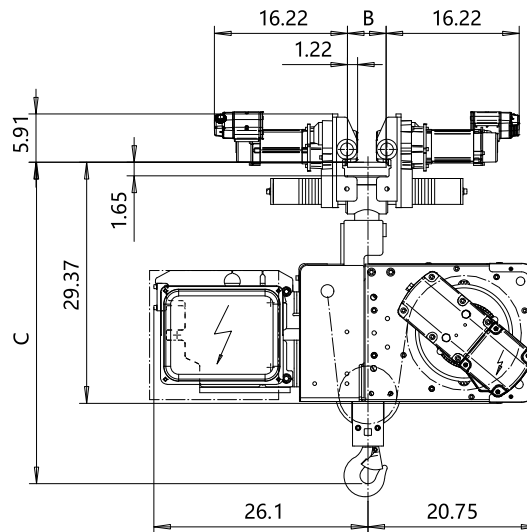
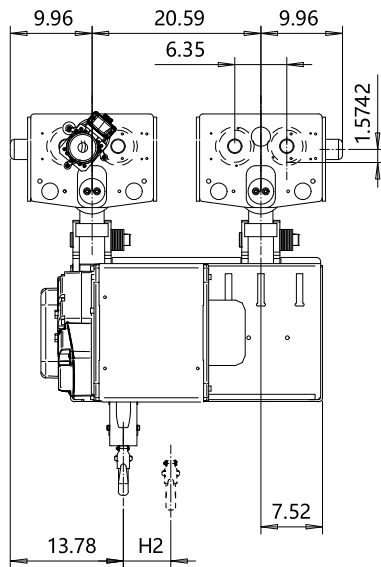

Track Radius	
Flange width B	R min
3.54 - 4.29	8'-2 7/16"
4.33 - 4.68	6'-6 3/4"
4.72 - 13.78	4'-11 1/16"

Headroom - C dimension	
Standard	42 3/4"
with HS22 Hook operated limit switch	43 1/8"

Motor	P3	P4	A3	S3	S5
MOT (in)	18.7	22.6	17.6	20.7	23.7
Weight (lb)	77	117	71	62	117

Hoist Dimensions				
HOL	Length	H2	M1	Weight
(ft)	code	(inch)	(inch)	(lb)
39'-4"	B	3.85	14.03	1036
59'-0"	C	5.78	17.95	1080
78'-8"	D	7.79	21.89	1168
98'-5"	E	10.15	26.62	1190

Load	Class
(TON)	ASME
1 1/2	H4 +
2	H4 +
2 1/2	H4

This document is the absolute property of R&M Materials Handling, Inc. This document must not be copied without the written permission of R&M Materials Handling, Inc. The contents thereof must not be disclosed to a third party nor be used for any unauthorized purpose. Contravention will be prosecuted.

ETTVPH Design	ETTVPH Chd	Appd	Ref Drawing	QB-N-02
2004-12-23 Date	TROLLEY; NORMAL HEADROOM			
SLEQDOCV Owner Dept	CURVED TRACK; 2 ROPE FALLS			
	R&M MATERIALS HANDLING, INC. HOIST & CRANE PRODUCTS SPRINGFIELD, OHIO			
D003840-A				Issue 6