

DOUBLE GIRDER, MEDIUM, 4 PART SINGLE

Hoist type:

SX4 041...D0

US-60Hz

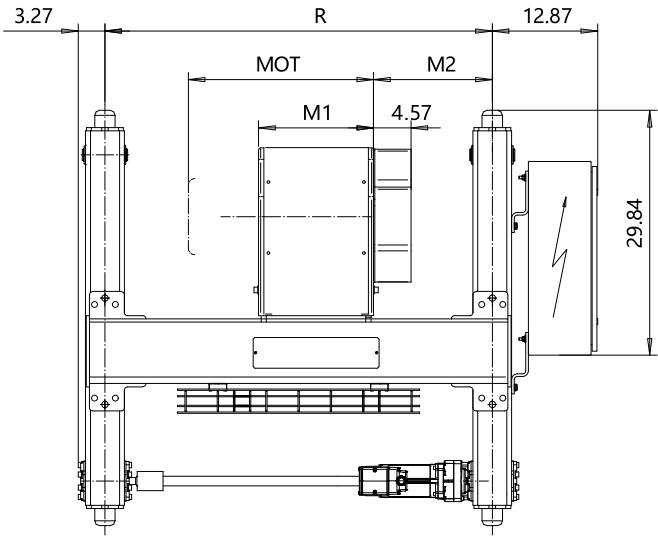
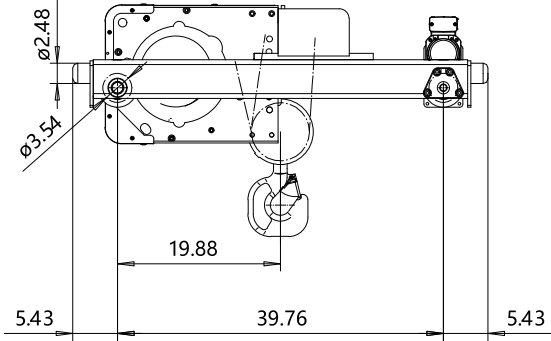
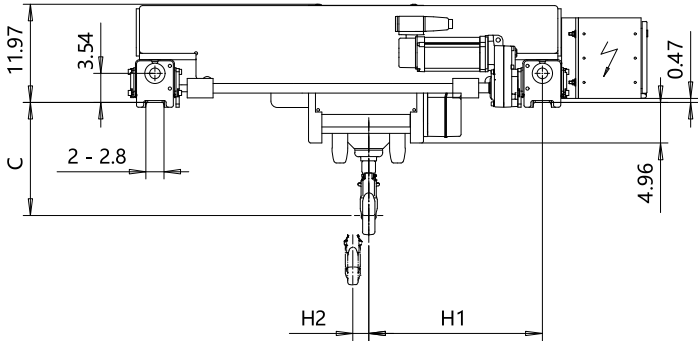

Headroom - C dimension	
Standard	19 5/16"
with HS22 Hook operated limit switch	19 5/16"

Motor	P3	P4	A3	S3	S5
MOT (in)	18.7	22.6	17.6	20.7	23.7
Weight (lb)	77	117	71	62	117

HOL (ft)	Length code	M1 (inch)	M2 (inch)	H1 (inch)	H2 (inch)	min R (ft)	Approx Weight (lb)
19'-8"	B	14.03	14.5	21.1	1.9	3'-11 1/4"	695
29'-6"	C	17.95	14.5	21.1	2.9	3'-11 1/4"	717
39'-4"	D	21.89	18.43	25.1	3.9	4'-7 1/8"	750
49'-3"	E	26.62	18.43	25.1	5.1	4'-7 1/8"	794

Load (TON)	Class
3	H4 +
4	H4 +
5	H4

Note: minR is minimum rail gauge when second brake is supplied
 Standard rail gauges are 3'-11 1/4", 4'-7 1/8", 5'-6 7/8", and 6'-6 3/4"
 H1, M2 calculated at minR and weight calculated with P3 motor.

This document is the absolute property of R&M Materials Handling, Inc. This document must not be copied
 R&M Materials Handling, Inc.
 The contents thereof must not be disclosed to a third party nor be used for any unauthorized purpose. Contravention will be prosecuted.

Design	Chd	Appd	Ref Drawing	QB-M-04
Date	TROLLEY; DOUBLE GIRDER			1:10 Fo/Mir
SLEQENG1 Owner Dept	MEDIUM, 4 ROPE FALLS			
R&M MATERIALS HANDLING INC.	R&M MATERIALS HANDLING, INC. HOIST & CRANE PRODUCTS SPRINGFIELD, OHIO			Issue 10
D002095-A				