

NORMAL HEADROOM, CURVED TRACK; 4 PART SINGLE

Hoist type:

SX4 041...N0

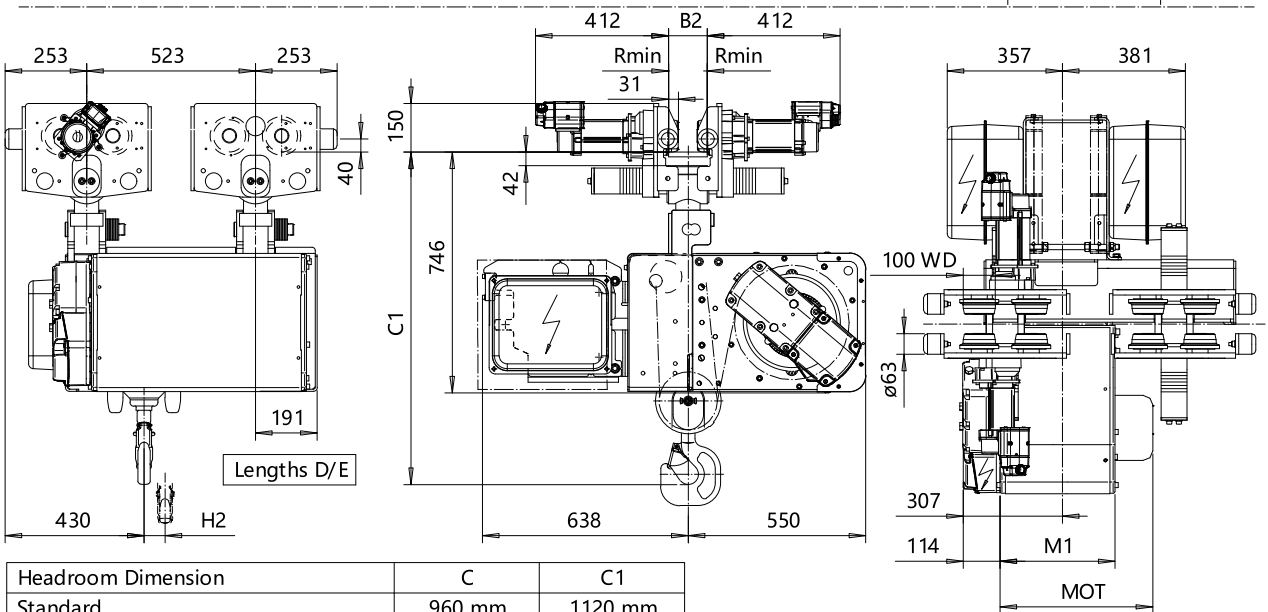
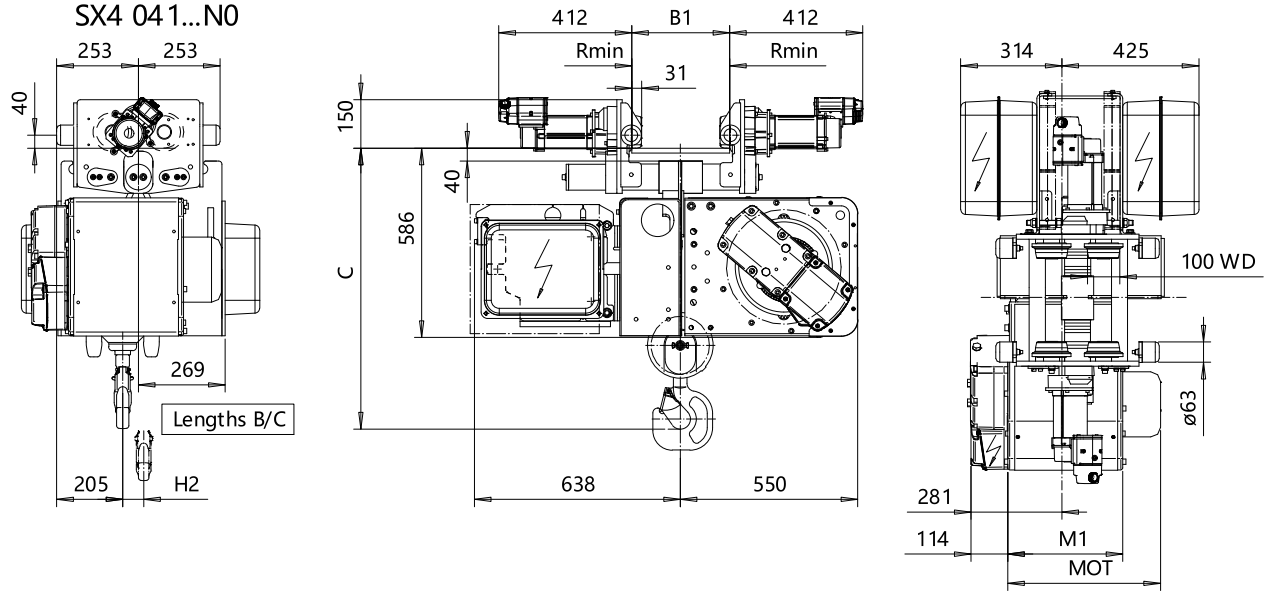

Headroom Dimension	C	C1
Standard	960 mm	1120 mm
with HS22 Hook operated limit switch	960 mm	1120 mm

Motor	P3	P4	A3	S3	S5
MOT (mm)	476	574	446	526	602
Weight (kg)	35	53	32	28	53

Load (kg)	Class
3000	Fem/ISO 3m/M6
4000	3m/M6
5000	2m/M5

Hoist Dimensions				
HOL (m)	Length code	H2 (mm)	M1 (mm)	Approx Weight (kg)
6	B	49	356	413
9	C	73	456	453
12	D	97	556	603
15	E	121	676	618

Track Radius		
Flange B1	Flange B2	R min
80 - 109	90 - 109	2500
110 - 119	110 - 119	2000
120 - 450	120 - 350	1500

This document is the absolute property of R&M Materials Handling, Inc. This document must not be copied without the written permission of R&M Materials Handling, Inc. The contents thereof must not be disclosed to a third party nor be used for any unauthorized purpose. Contravention will be prosecuted.

ETVPH Design 2004-12-23 Date	ETVPH Chd Appd	Ref Drawing	QB-N-04
SLEDDOCV Owner Dept	TROLLEY; NORMAL HEADROOM CURVED TRACK; 4 ROPE FALLS		1:10 FoMar
R&M MATERIALS HANDLING INC.	R&M MATERIALS HANDLING, INC. HOIST & CRANE PRODUCTS SPRINGFIELD, OHIO	D003841-A	Issue 6