

Double Girder Hoist EXSX4, REEVING: 021; Class I, Division 2

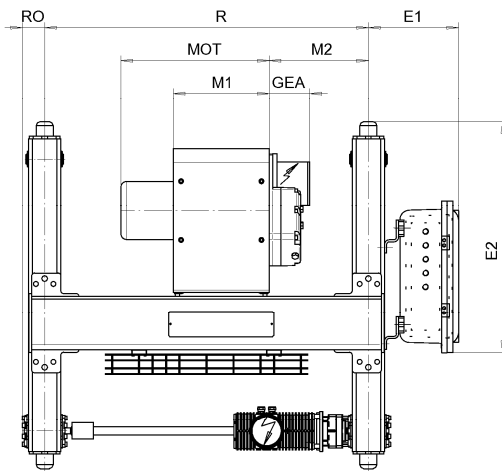
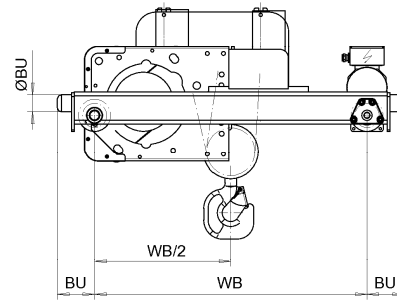
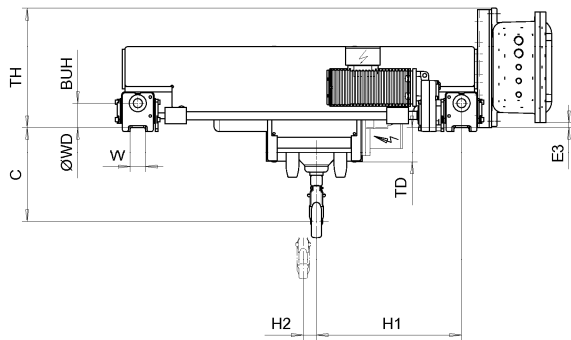

D007631-A

**Hoist dimensions**

HOL ft	Length code	M1 inch	M2 inch	H1 inch	H2 inch	Min R inch	Weight lb
39'-4"	B	14.02	14.49	18.07	3.74	47.24	1127
59'-1"	C	17.95	14.49	18.07	5.67	47.24	1147
78'-9"	D	21.89	18.43	22.01	7.6	55.12	1208
98'-5"	E	26.61	18.43	22.01	9.92	55.12	1241

**Motor dimensions**

Motor	P1	P3
MOT (inch)	15.2	18.62
Weight (lb)	46	77

**Traveling dimensions**

Motor	MF06LA
Weight (lb)	17

**Trolley dimensions**

C	ØWD	ØBU	BU	BUH	E1	E2	E3	GEA	RO	TD	TH
16.73	3.54	2.48	5.43	3.46	13.19	33.74	0.71	5.91	3.27	5.16	17.56
WB	W min	W max									
39.76	1.97	2.76									

D007631\_A  
252843

Note: Weight calculated with P1 and MF06LA motors.

Note: All dimensions in inch.

Note: Min R with service platform.

Note: Standard rail gauges: 47.2, 55.1, 66.9 and 78.7.

Note: Flangeless wheels available.