

Normal Headroom Hoist EXSX4, REEVING: 021; Class I, Division 1

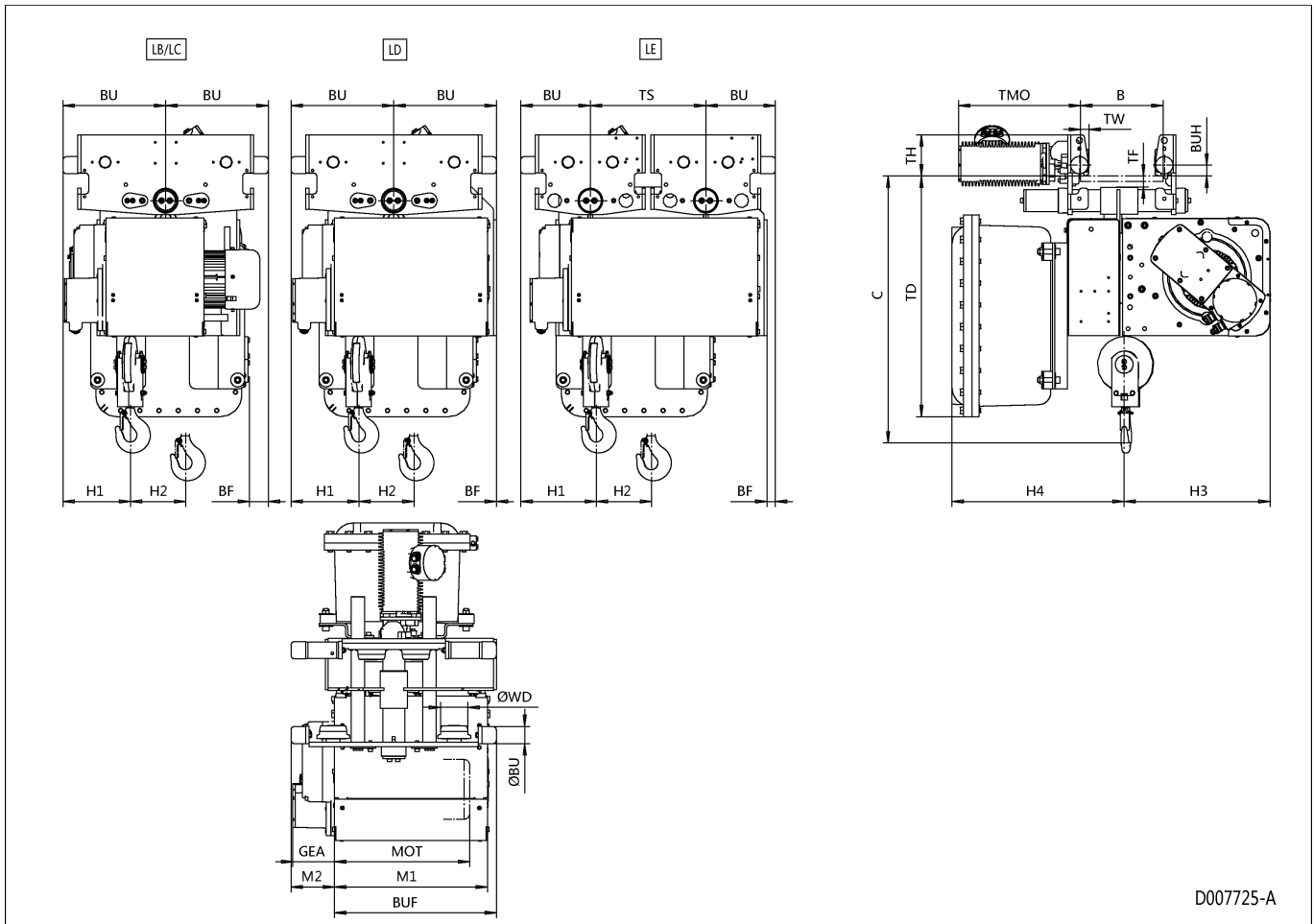

D007725-A

Hoist dimensions

HOL m	Length code	M1 mm	M2 mm	BUF mm	H1 mm	H2 mm	H3 mm	H3* mm	H4 mm	Weight kg
12	B	356	158	588	244	98	522	538	634	565
18	C	456	158	588	244	147	522	538	634	590
24	D	556	158	588	244	198	522	538	634	610
30	E	676	185	741	274	258	522	538	634	675

Motor dimensions

Motor	E1	E2
MOT (mm)	565	565
Weight (kg)	70	70

Traveling dimensions

Motor	MF07E
TMO (mm)	445
Weight (kg)	13

Trolley dimensions

B min	B max	C	ØWD	ØBU	BUH	GEA	TD	TF	TH	TW
120	450	835	100	63	40	151	876	40	150	31

Length code	BF	BU	TS
B/C	68	373	-
D	0	373	-
E	31	253	420