

Normal Headroom Hoist EXSX4, REEVING: 021; Class I, Division 1

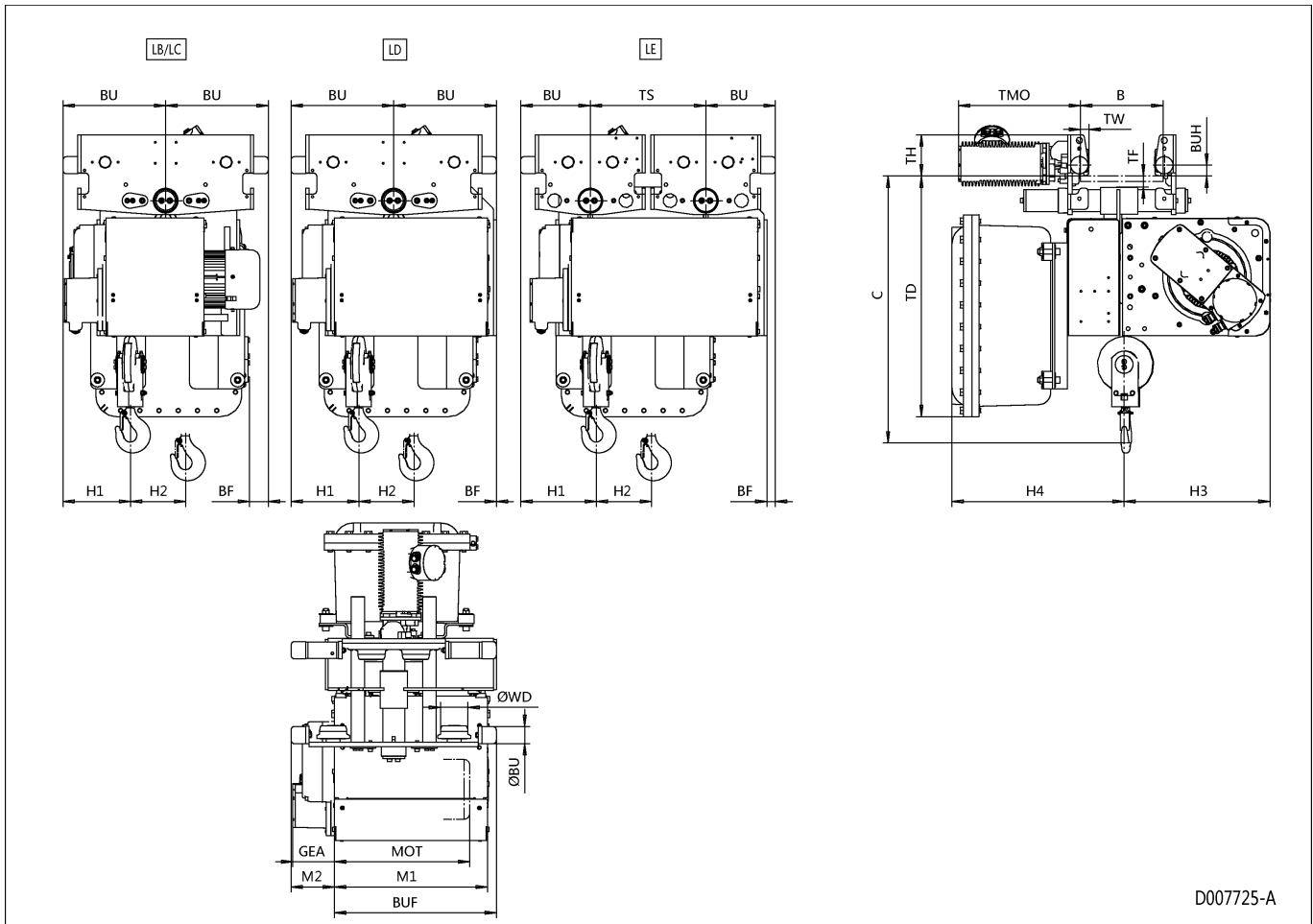

D007725-A

Hoist dimensions

HOL ft	Length code	M1 Inch	M2 Inch	BUF Inch	H1 Inch	H2 Inch	H3 Inch	H3* Inch	H4 Inch	Weight lb
39'-4"	B	14.02	6.22	23.15	9.61	3.86	20.55	21.18	24.96	1246
59'-1"	C	17.95	6.22	23.15	9.61	5.79	20.55	21.18	24.96	1301
78'-9"	D	21.89	6.22	23.15	9.61	7.8	20.55	21.18	24.96	1345
98'-5"	E	26.61	7.28	29.17	10.79	10.16	20.55	21.18	24.96	1488

Motor dimensions

Motor	E1	E2
MOT (Inch)	22.24	22.24
Weight (lb)	154	154

Travelling dimensions

Motor	MF07E
TMO (Inch)	17.52
Weight (lb)	29

Trolley dimensions

B min	B max	C	ØWD	ØBU	BUH	GEA	TD	TF	TH	TW
4.72	17.72	32.87	3.94	2.48	1.57	5.94	34.49	1.57	5.91	1.22

Length code	BF	BU	TS
B/C	2.68	14.69	-
D	0	14.69	-
E	1.22	9.96	16.54