

Double Girder Hoist EXSX4, REEVING: 041; Class I, Division 2

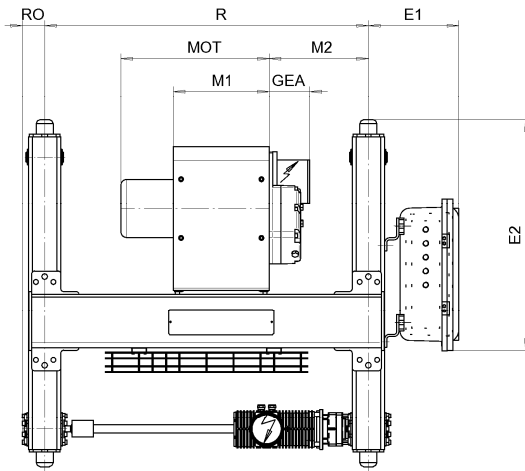
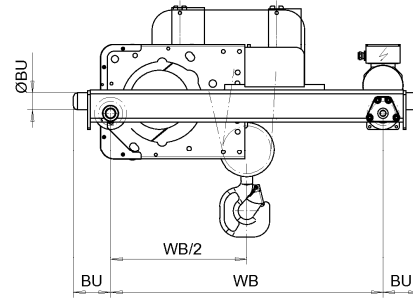
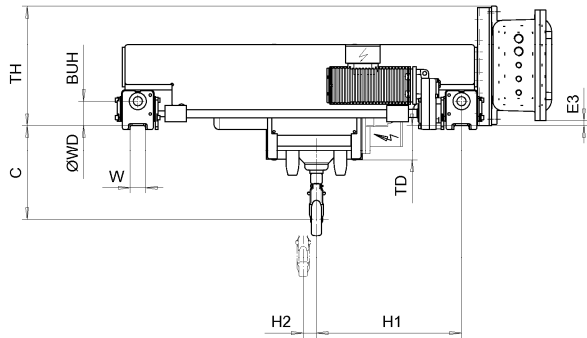

D007632-A

Hoist dimensions

HOL ft	Length code	M1 inch	M2 inch	H1 inch	H2 inch	Min R inch	Weight lb
19'-8"	B	14.02	14.49	21.14	1.93	47.24	1164
29'-6"	C	17.95	14.49	21.14	2.91	47.24	1182
39'-4"	D	21.89	18.43	25.08	3.9	55.12	1246
49'-3"	E	26.61	18.43	25.08	5.08	55.12	1281

Motor dimensions

Motor	P1	P3
MOT (inch)	15.2	18.62
Weight (lb)	46	77

Traveling dimensions

Motor	MF06LA
Weight (lb)	17

Trolley dimensions

C	ØWD	ØBU	BU	BUH	E1	E2	E3	GEA	RO	TD	TH
15.75	3.54	2.48	5.43	3.54	13.19	33.74	0.71	5.91	3.27	5.16	17.56
WB	W min	W max									
39.76	1.97	2.76									

D007632_A
252848

Note: Weight calculated with P1 and MF06LA motors.

Note: All dimensions in inch.

Note: Min R with service platform.

Note: Standard rail gauges: 47.2, 55.1, 66.9 and 78.7.

Note: Flangeless wheels available.