

Fixed Hoist EXSX4, REEVING: 041; Class I, Division 2

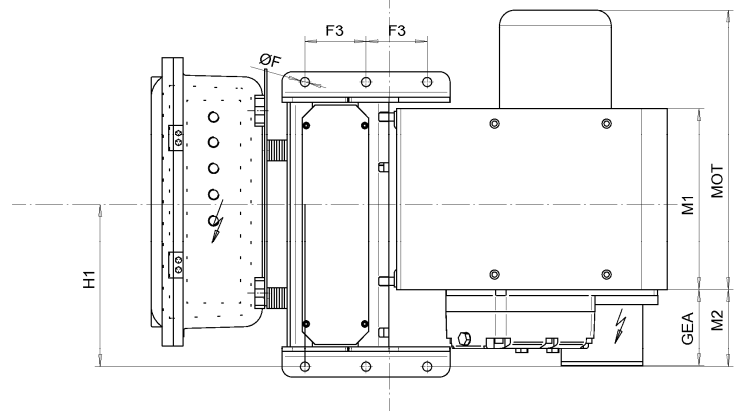
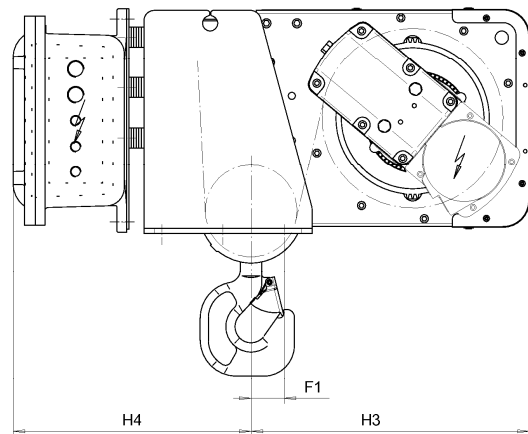
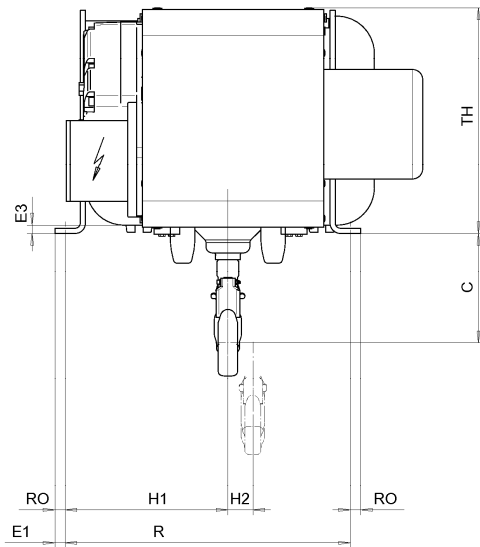

D007610-A

Hoist dimensions

HOL m	Length code	M1 mm	M2 mm	H1 mm	H2 mm	H3 mm	H3* mm	R mm	Weight kg
6	B	356	152	319.5	49	546	562	560	374
9	C	456	52	219.5	73	546	562	560	381
12	D	556	52	219.5	97	546	562	780	407
15	E	676	52	219.5	127	546	562	780	423

Motor dimensions

Motor	P1	P3
MOT (mm)	386	473
Weight (kg)	21	35

Trolley dimensions

C	ØF	E1	E3	F1	F3	GEA	H4	RO	TH		
215	18	20	16.1	65	120	150	466.7	20	445		

D007610_A
252700

Note: All dimensions in mm.

Note: Weight calculated with P1 motor.

* Please, disregard the dimension H3*.