

Fixed Hoist EXSX4, REEVING: 041; Class I, Division 2

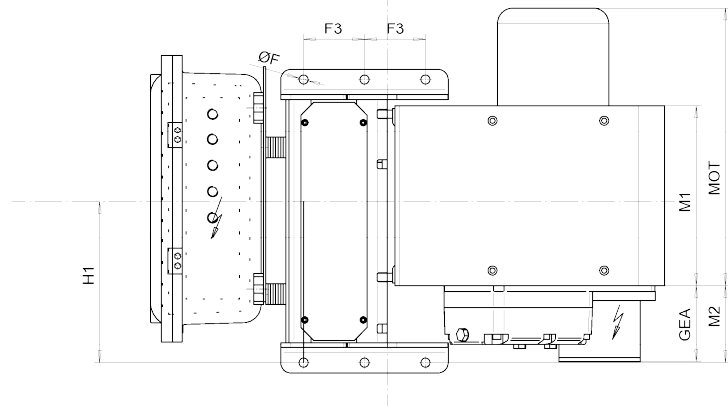
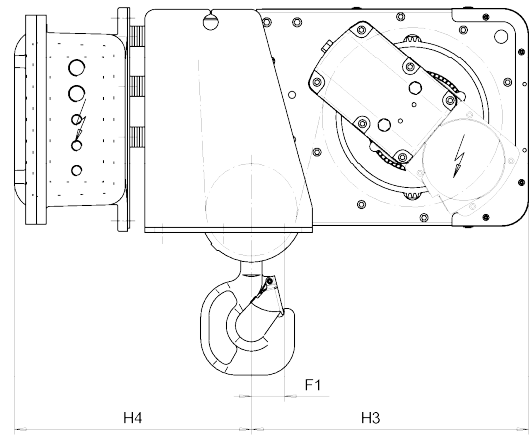
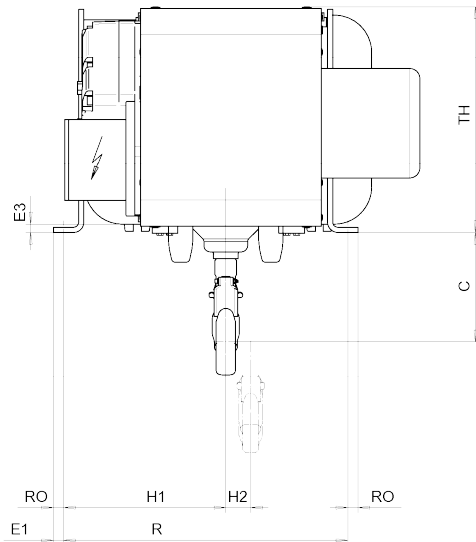

D007610-A

Hoist dimensions

HOL ft	Length code	M1 inch	M2 inch	H1 inch	H2 inch	H3 inch	H3* inch	R inch	Weight lb
19'-8"	B	14.02	5.98	12.58	1.93	21.5	22.13	22.05	825
29'-6"	C	17.95	2.05	8.64	2.87	21.5	22.13	22.05	840
39'-4"	D	21.89	2.05	8.64	3.82	21.5	22.13	30.71	897
49'-3"	E	26.61	2.05	8.64	5	21.5	22.13	30.71	933

Motor dimensions

Motor	P1	P3
MOT (inch)	15.2	18.62
Weight (lb)	46	77

Trolley dimensions

C	ØF	E1	E3	F1	F3	GEA	H4	RO	TH		
8.46	0.71	0.79	0.63	2.56	4.72	5.91	18.37	0.79	17.52		

D007610_A
252700

Note: All dimensions in inch.

Note: Weight calculated with P1 motor.

* Please, disregard the dimension H3*.