

FOOT MOUNT, 4 PART SINGLE
Hoist type:
SX5 041...F0

SI-50Hz

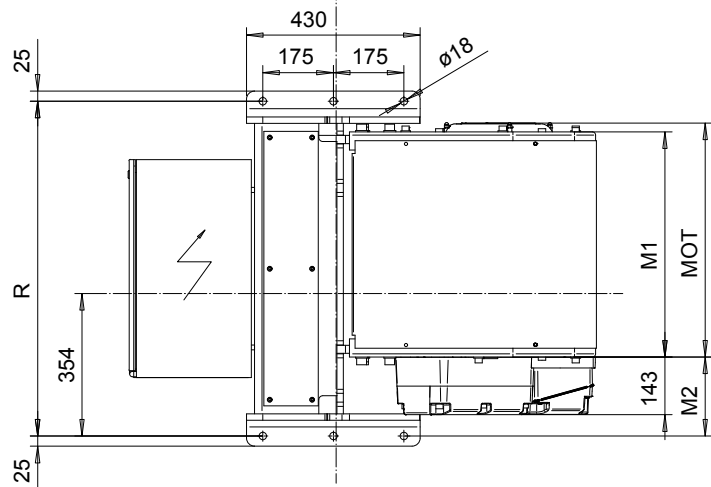
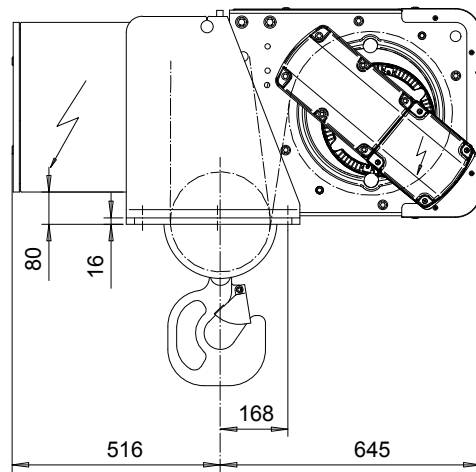
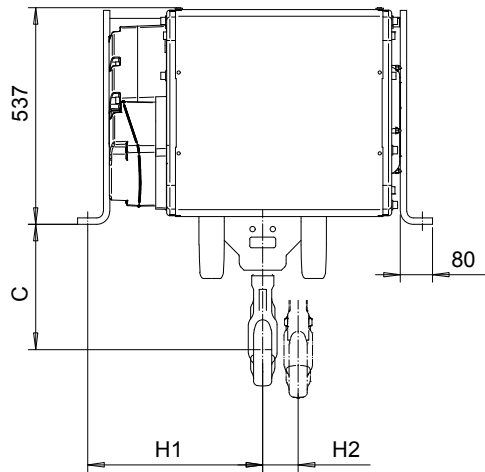

Motor	P5	P6	P7	A5	S5	S7
MOT (mm)	578	578	618	498	606	757
Weight (kg)	58	85	105	45	53	81

HOL	Length	M1	M2	H1	H2	R	Approx. Weight
(m)	code	(mm)	(mm)	(mm)	(mm)	(mm)	(kg)
9	D	558	196	434	88	830	445
12	E	678	76	314	118	830	460
16	F	828	76	314	156	1170	480
20	G	1018	76	314	204	1170	500

Load	Class
(kg)	Fem/ISO
5000	3m/M6
6300	3m/M6
8000	3m/M6
10000	2m/M5

Headroom - C dimension	
Standard	310 mm
with HS22 Hook operated limit switch	430 mm

Approx weight calculated with P5 motor.

This document is the absolute property of R&M Materials Handling, Inc. This document must not be copied without the written permission of R&M Materials Handling, Inc. The contents thereof must not be disclosed to a third party nor be used for any unauthorized purpose. Contravention will be prosecuted.

ETTPAL Design	ETTPAL Chd	Appd	Ref Drawing	QC-F-04
2002-06-29 Date	HOIST; FIXED			1:8
SLEQDQCV Owner Dept	4 ROPE FALLS			Folder
R&M MATERIALS HANDLING INC.	R&M MATERIALS HANDLING INC HOIST & CRANE PRODUCTS SPRINGFIELD, OHIO			Issue 7
D002116-A				