

DOUBLE GIRDER, ADJUSTABLE LOAD BEAM, 2 PART SINGLE
 Hoist type:
 SX5 021...D0

SI-50Hz

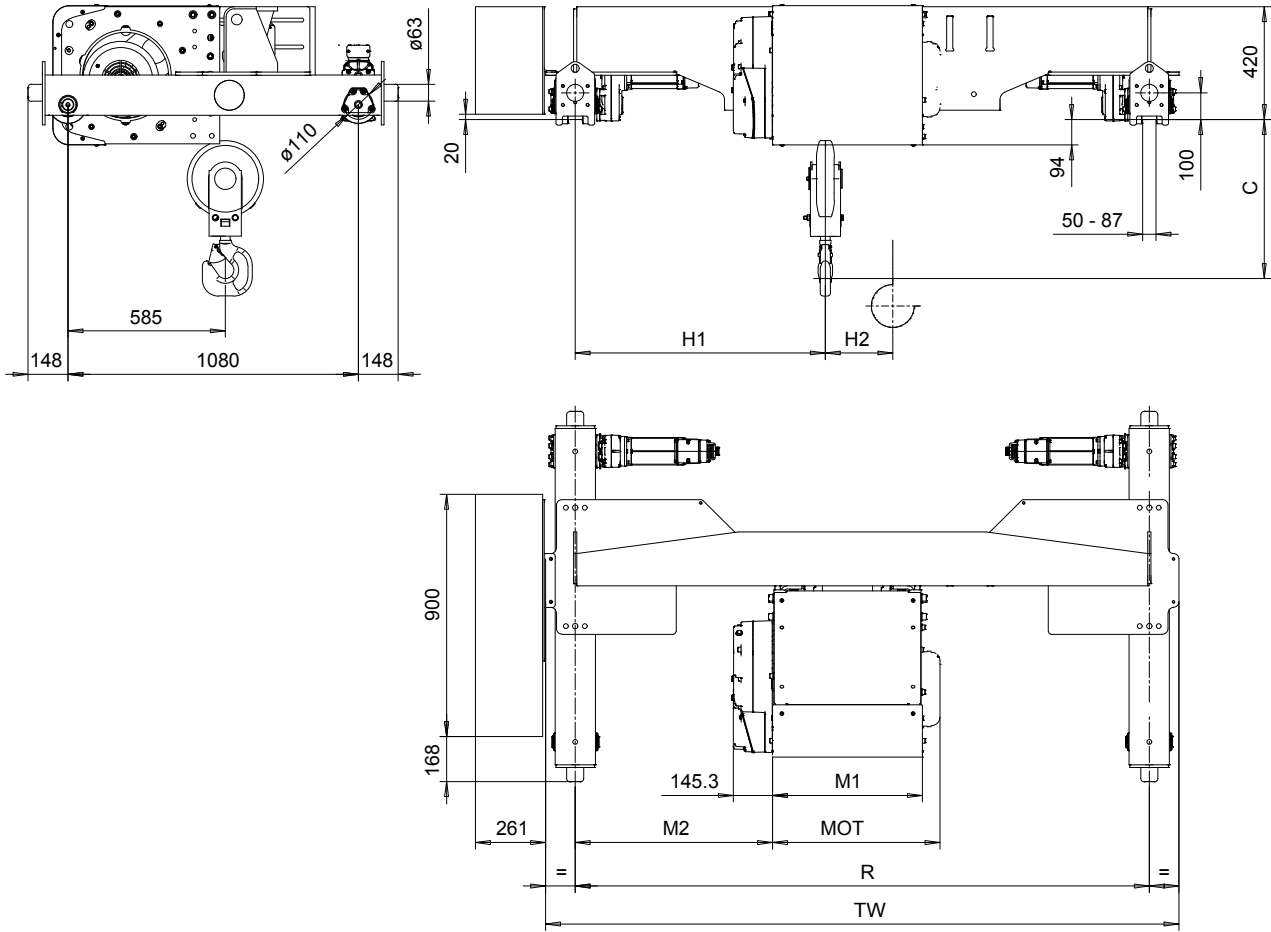

Motor	P5	P6	P7	A5	S5	S7
MOT (mm)	578	578	618	498	606	757
Weight (kg)	58	85	105	45	53	81

Load (kg)	Class
4000	Fem/ISO
5000	3m/M6
	2m/M5

HOL (m)	Length code	M1 (mm)	M2 (mm)	H1 (mm)	H2 (mm)	TW (mm)	Min R (mm)	Max R (mm)	Approx Weight (kg)
18	D	558	428	625	176	2354	1524	2134	670
24	E	678	428	625	235	2354	1524	2134	700
32	F	828	428	625	309	2354	1524	2134	745

Headroom - C dimension	
Standard	521 mm
with HS22 Hook operated limit switch	571 mm

Note: H1 and M2 are calculated from Min R.
 Special rail gauges from 1524 mm to 2134 mm
 Approx weight calculated with P5 motor

This document is the absolute property of R&M Materials Handling, Inc. This document must not be copied without the written permission of R&M Materials Handling, Inc. The contents thereof must not be disclosed to a third party nor be used for any unauthorized purpose. Contravention will be prosecuted.

ETTPAL Design	ETTPAL Chd	Appd	Ref Drawing	QC-ALB-02
2018-05-12 Date	TROLLEY; DOUBLE GIRDER			1:12
SLEQDQCV Owner Dept	ADJUSTABLE LOAD BEAM, 2 ROPE FALLS			Folder
R&M MATERIALS HANDLING INC.	R&M MATERIALS HANDLING, INC. HOIST & CRANE PRODUCTS SPRINGFIELD, OHIO	D53825437-vxp1-1		Issue 1