

DOUBLE GIRDER, MEDIUM, 2 PART SINGLE
Hoist type:
SX5 021...D0

SI

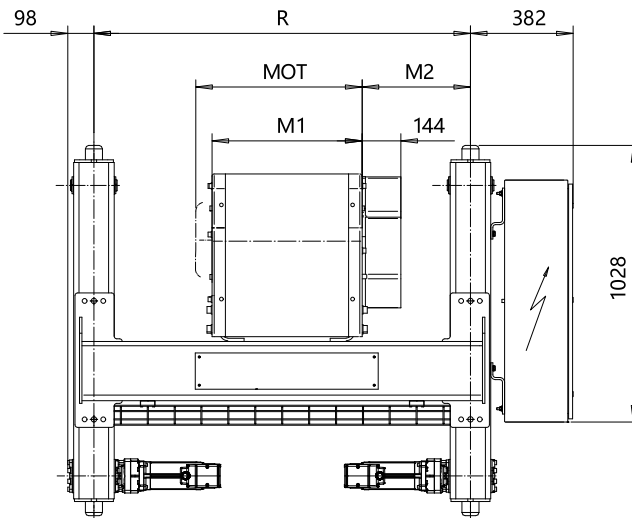
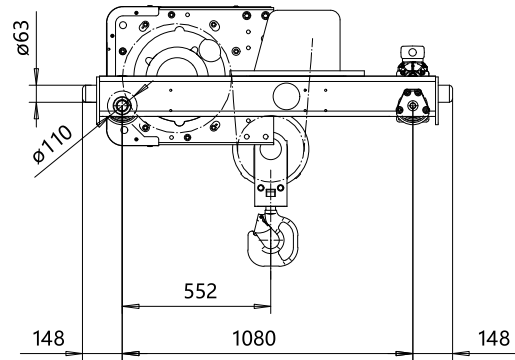
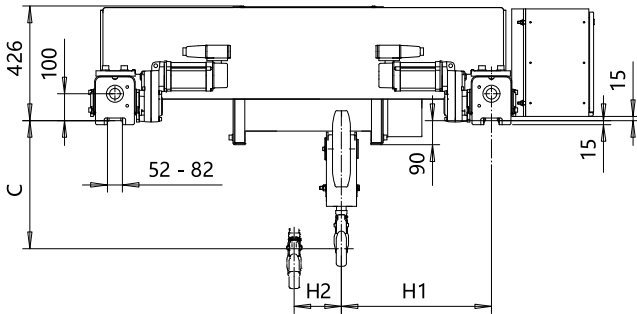

Motor	P5	P6	P7	A5	S5	S7
MOT (mm)	578	578	618	498	606	757
Weight (kg)	58	85	105	45	53	81

HOL	Length	M1	M2	H1	H2	Min R	Approx Weight
(m)	code	(mm)	(mm)	(mm)	(mm)	(mm)	(kg)
18	D	558	403	640	176	1400	670
24	E	678	403	640	235	1400	700
32	F	828	516	753	309	1700	745
40	G	1018	666	903	403	2000	785

Load	Class
(kg)	Fem/ISO
4000	3m/M6
5000	2m/M5

Headroom - C dimension	
Standard	530 mm
with HS22 Hook operated limit switch	640 mm

Note: minR is minimum rail gauge when second brake is supplied
 Standard rail gauges are 1400, 1700, and 2000 mm
 Approx weight calculated with P5 motor

This document is the absolute property of R&M Materials Handling, Inc. This document must not be copied without the written permission of R&M Materials Handling, Inc. The contents thereof must not be disclosed to a third party nor be used for any unauthorized purpose. Contravention will be prosecuted.

ETFPAL Design	ETFPAL Chd	Appd	Ref Drawing	QC-M-02
2002-08-29 Date	TROLLEY; DOUBLE GIRDER			1 of 12
SLEQDOCV Owner Dept	MEDIUM, 2 ROPE FALLS			FoMbr
R&M MATERIALS HANDLING INC.	R&M MATERIALS HANDLING, INC. HOIST & CRANE PRODUCTS SPRINGFIELD, OHIO	D002113-A		Issue 13