

**NORMAL HEADROOM, 2 PART SINGLE**

Hoist type:  
SX5 021...N0

SI

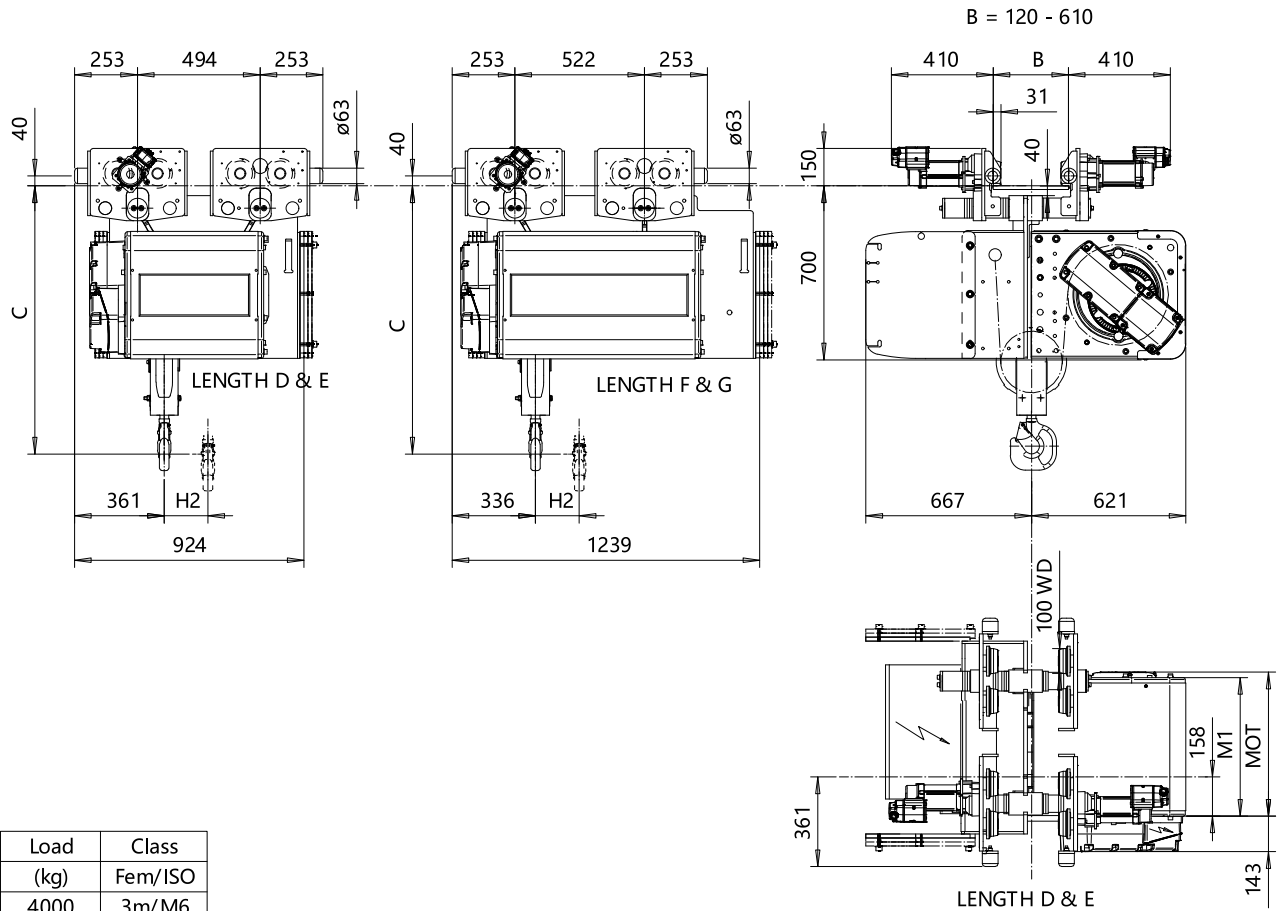

Load (kg)	Class
4000	Fem/ISO
5000	3m/M6
	2m/M5

Motor	P5	P6	P7	A5	S5	S7
MOT (mm)	578	578	618	498	606	757
Weight (kg)	58	85	105	45	53	81

HOL (m)	Length code	M1 (mm)	H2 (mm)	Approx Weight (kg)
18	D	558	176	750
24	E	678	235	820
32	F	828	309	900
40	G	1018	403	960

Headroom - C dimension	
Standard	1090 mm
with HS22 Hook operated limit switch	1200 mm

Approx. Weight calculated with P5 motor.

This document is the absolute property of R&M Materials Handling, Inc. This document must not be copied without the written permission of R&M Materials Handling, Inc. The contents thereof must not be disclosed to a third party nor be used for any unauthorized purpose. Contravention will be prosecuted.

ETPAL Design	ETPAL Chd	Appd	Ref Drawing	QC-N-02
2002-08-29 Date	TROLLEY; NORMAL HEADROOM			1 of 13
SLEDDOCV Owner Dept	2 ROPE FALLS			For Mar
R&M MATERIALS HANDLING INC.	R&M MATERIALS HANDLING INC. HOIST & CRANE PRODUCTS SPRINGFIELD, OHIO	D002114-A		Issue 10