

NORMAL HEADROOM, CURVED TRACK, 2 PART SINGLE

Hoist type:

SX5 021...N0

SI

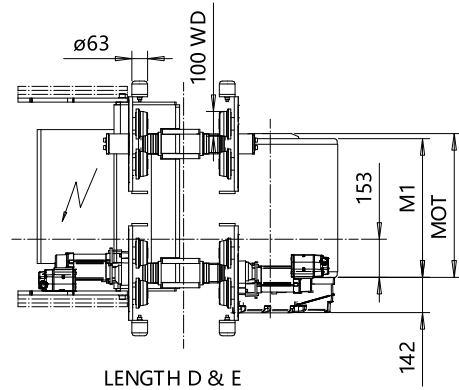
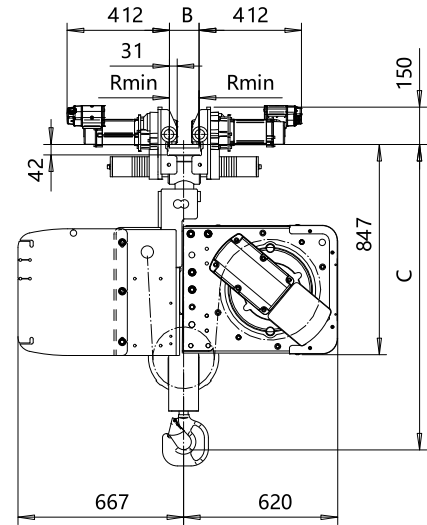
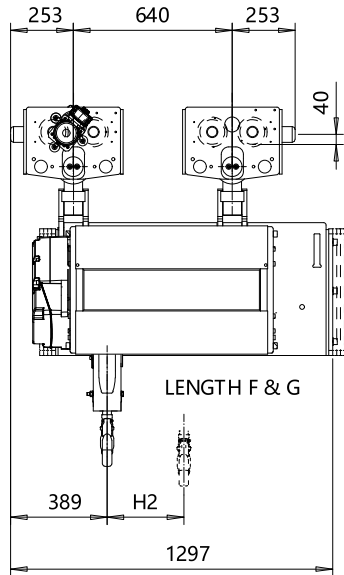
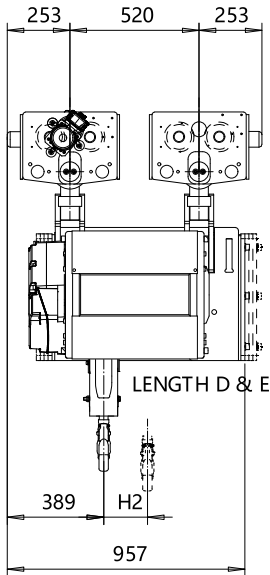

TRACK RADIUS	
Flange, B (mm)	R min (mm)
90 - 109	2500
110 - 119	2000
120 - 350	1500

Load (kg)	Class Fem/ISO
4000	3m/M6
5000	2m/M5

Motor	P5	P6	P7	A5	S5	S7
MOT (mm)	578	578	618	498	606	757
Weight (kg)	58	85	105	45	53	81

HOL (m)	Length code	H2 (mm)	M1 (mm)	Approx Weight (kg)
18	D	176	558	810
24	E	235	678	870
32	F	309	828	940
40	G	403	1018	1000

Headroom - C dimension	
Standard	1240 mm
with HS22 Hook operated limit switch	1350 mm

Approx. Weight calculated with P5 motor.

This document is the absolute property of R&M Materials Handling, Inc. This document must not be copied without the written permission of R&M Materials Handling, Inc. The contents thereof must not be disclosed to a third party nor be used for any unauthorized purpose. Contravention will be prosecuted.

ETTVPH Design	ETTVPH Chd	Appd	Ref Drawing	QC-N-02
2005-06-20 Date	TROLLEY; NORMAL HEADROOM			1 of 13
SLEQDOCV Owner Dept	CURVED TRACK, 2 ROPE FALLS			FoMbr
R&M MATERIALS HANDLING INC.	R&M MATERIALS HANDLING INC. HOIST & CRANE PRODUCTS SPRINGFIELD, OHIO	D004135-A		Issue 6