

NORMAL HEADROOM, CURVED TRACK, 2 PART SINGLE

Hoist type:

SX5 021...N0

US-60Hz

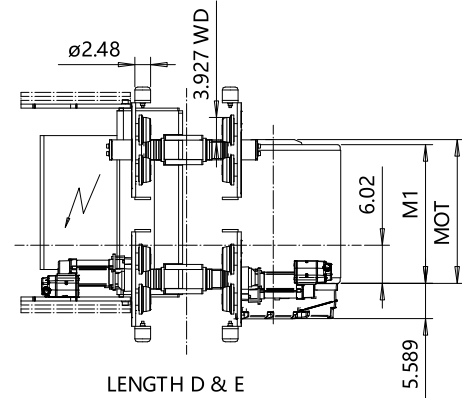
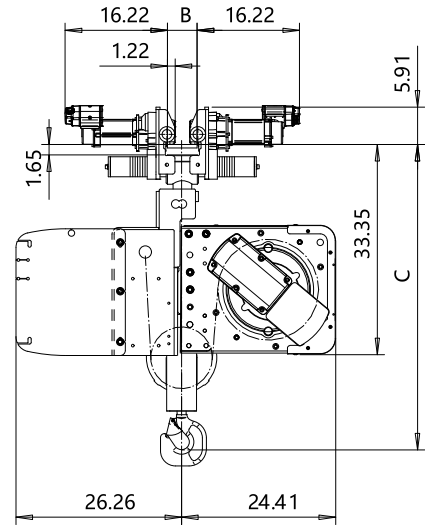
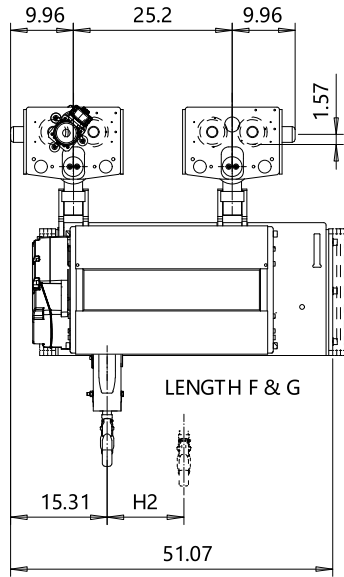
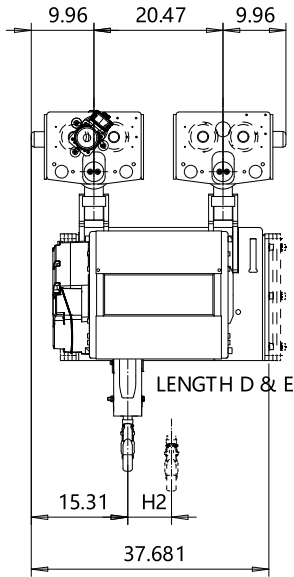

TRACK RADIUS	
Flange, B (inch)	R min
3.54 - 4.29	8'-2 7/16"
4.33 - 4.67	6'-6 3/4"
4.72 - 13.78	4'-11 1/16"

Load (ton)	Class ASME
4	H4 +
5	H4

Motor	P5	P6	P7	A5	S5	S7
MOT (in)	22.76	22.76	24.33	19.61	23.86	29.8
Weight (lb)	128	187	231	99	117	179

HOL (ft)	Length code	H2 (inch)	M1 (inch)	Approx Weight (lb)
59'-0"	D	6.92	21.97	1786
78'-8"	E	9.25	26.69	1918
104'-11"	F	12.16	32.6	2072
131'-2"	G	15.86	40.09	2205

Headroom - C dimension	
Standard	48 13/16"
with HS22 Hook operated limit switch	53 3/16"

Approx. Weight calculated with P5 motor.

This document is the absolute property of R&M Materials Handling, Inc. This document must not be copied without the written permission of R&M Materials Handling, Inc. The contents thereof must not be disclosed to a third party nor be used for any unauthorized purpose. Contravention will be prosecuted.

ETTVPH Design	ETTVPH Chd	Appd	Ref Drawing	QC-N-02
2005-06-20 Date	TROLLEY; NORMAL HEADROOM			1-13
SLEQDOCV Owner Dept	CURVED TRACK, 2 ROPE FALLS			FoMbr
R&M MATERIALS HANDLING INC.	R&M MATERIALS HANDLING INC HOIST & CRANE PRODUCTS SPRINGFIELD, OHIO	D004135-A		Issue 6