

DOUBLE GIRDER, MEDIUM, 2 PART DOUBLE
Hoist type:
SX5 022...D0

SI-50Hz

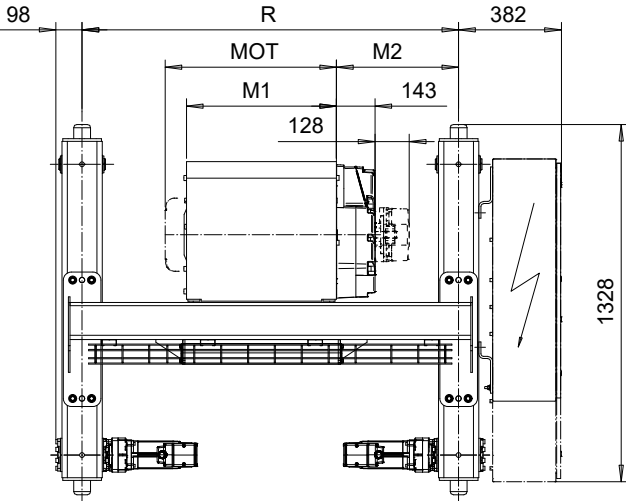
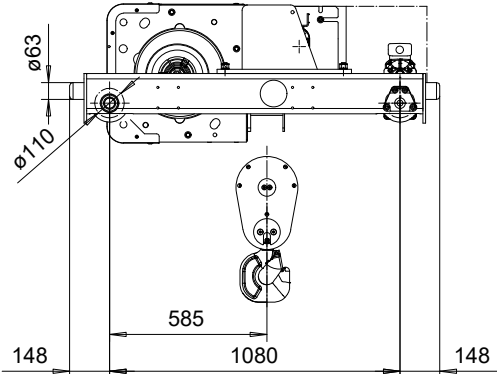
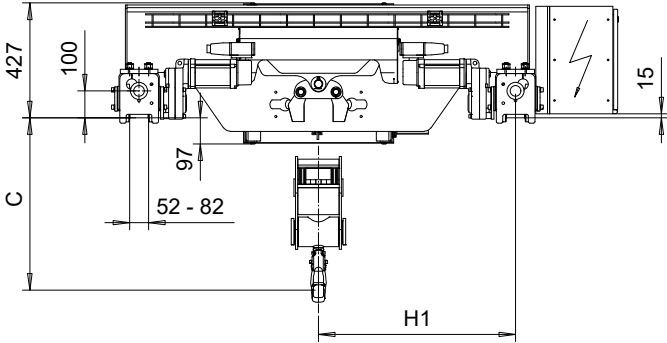

Headroom - C dimension	
Standard	641 mm
with HS22 Hook operated limit switch	691 mm

Motor	P5	P6	P7	A5	S5	S7
MOT (mm)	578	578	618	498	606	757
Weight (kg)	58	85	105	45	53	81

Load (kg)	Class Fem/ISO
4000	3m/M6
5000	2m/M5

HOL (m)	Length code	H1 (mm)	M1 (mm)	M2 (mm)	min R (mm)	Approx. Weight (kg)
8.5	D	733	558	454	1400	660
13	E	733	678	394	1400	680
18	F	883	828	469	1700	730
25	G	883	1018	374	1700	760
33.5	H	1033	1268	399	2000	840
46	J	1233	1618	424	2400	925

Note:
 R is standard gauge, minimum gauge with second brake or service platform
 Primary brake is mounted on gearcase for drum lengths H and J
 Standard rail gauge increments: 1400, 1700, 2000, and 2400 mm
 Apporx. Weight calculated with P5 motor.

This document is the absolute property of R&M Materials Handling, Inc. This document must not be copied without the written permission of R&M Materials Handling, Inc. The contents thereof must not be disclosed to a third party nor be used for any unauthorized purpose. Contravention will be prosecuted.

ETTPAL	ETTPAL	QC-M-22
Design	Chd	Appot
2002-08-30	TROLLEY; DOUBLE GIRDER	
Date	MEDIUM, 2x2 ROPE FALLS	
SLEQDQCV	Folder	
Owner Dept	Issue	
R&M MATERIALS HANDLING INC.	R&M MATERIALS HANDLING, INC. HOIST & CRANE PRODUCTS SPRINGFIELD, OHIO	D007171-A
D007171-a_3		4