

DOUBLE GIRDER, MEDIUM, 2 PART DOUBLE
Hoist type:
SX5 022...D0

US-60Hz

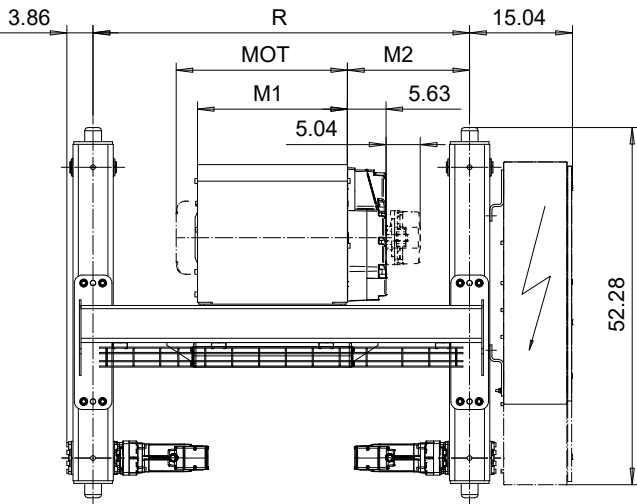
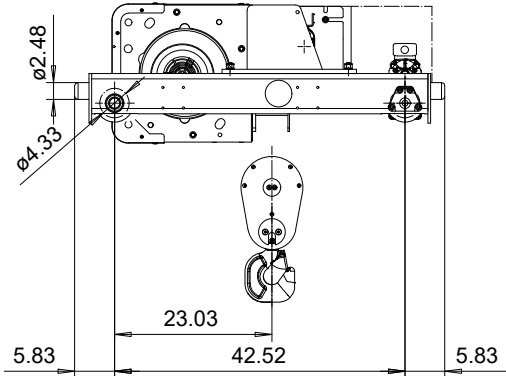
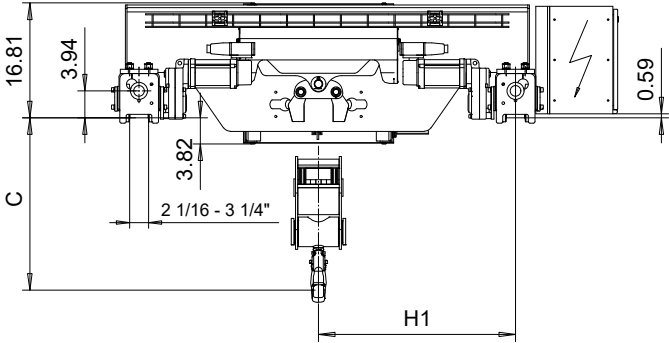

Headroom - C dimension	
Standard	25.22"
with HS22 Hook operated limit switch	27.22"

Motor	P5	P6	P7	A5	S5	S7
MOT (in)	22.76	22.76	24.33	19.61	23.86	29.8
Weight (lb)	128	187	231	99	117	179

Load (TON)	Class ASME
4	H4+
5	H4

HOL (ft)	Length code	H1 (inch)	M1 (inch)	M2 (inch)	R (inch)	Approx. Weight (lb)
27'-10"	D	28.86	21.97	17.87	55.12	1455
42'-7"	E	28.86	26.69	15.51	55.12	1499
59'-0"	F	34.76	32.6	18.46	66.93	1609
82'-0"	G	34.76	40.08	14.72	66.93	1676
109'-10"	H	40.67	49.92	15.71	78.74	1852
150'-11"	J	48.54	63.7	16.69	94.49	2039

Note:
 R is standard gauge, minimum gauge with second brake or service platform
 Primary brake is mounted on gearcase for drum lengths H and J
 Standard rail gauge increments: 4'-7 1/8", 5'-6 7/8", 6'-6 3/4", 7'-10 1/2"
 Approx. Weight calculated with P5 motor.

This document is the absolute property of R&M Materials Handling, Inc. This document must not be copied without the written permission of R&M Materials Handling, Inc. The contents thereof must not be disclosed to a third party nor be used for any unauthorized purpose. Contravention will be prosecuted.

ETTPAL Design	ETTPAL Chd	Appt	Ref Drawing	QC-M-22
2002-08-30 Date	TROLLEY; DOUBLE GIRDER			
SLEQDQCV Owner Dept	MEDIUM, 2x2 ROPE FALLS			
R&M MATERIALS HANDLING INC.	R&M MATERIALS HANDLING, INC HOIST & CRANE PRODUCTS SPRINGFIELD, OHIO	D007171-A		Issue 4