

DOUBLE GIRDER, HIGH CLEARANCE, 2 PART DOUBLE
Hoist type:
SX5 022...DH

US-60Hz

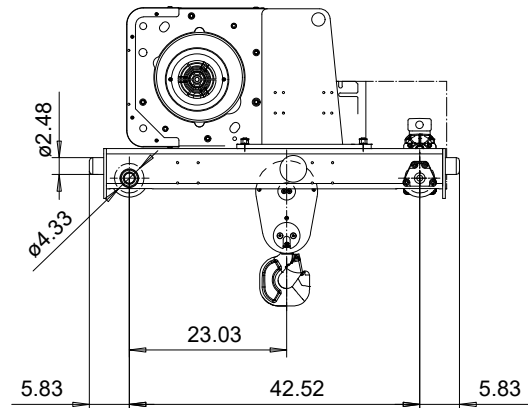
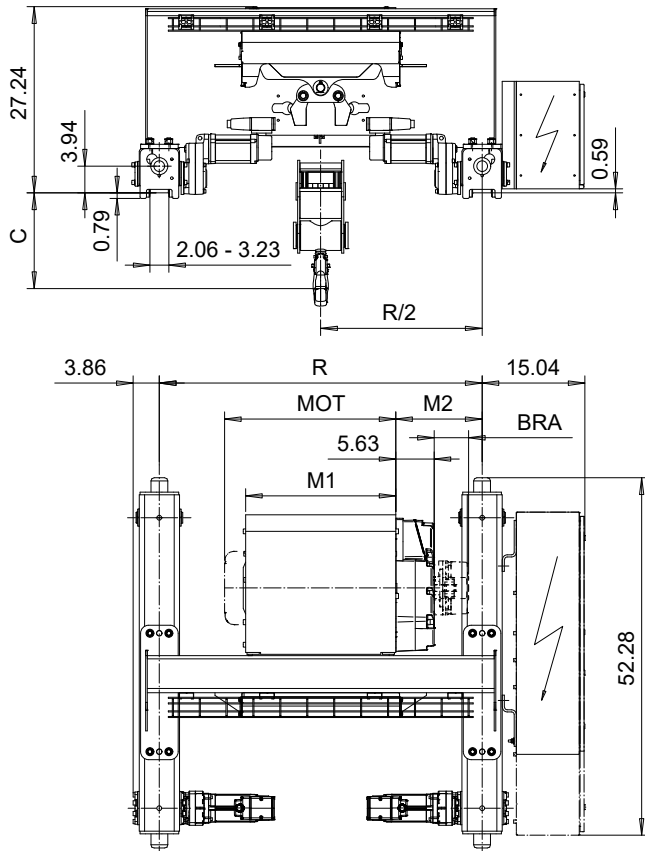

Motor	P5	P6	P7	A5	S5	S7
MOT (in)	22.76	22.76	24.33	19.61	23.86	29.8
Weight (lb)	128	187	231	99	117	179

HOL (ft)	Length code	M1 (inch)	M2 (inch)	BRA (inch)	Min R	Approx Weight (lb)
27'-10"	D	21.97	15.87	-	3'-11 1/4"	1488
42'-7"	E	26.69	15.87	-	3'-11 1/4"	1532
59'-0"	F	32.6	20.31	-	4'-7 1/8"	1620
82'-0"	G	40.08	26.22	-	5'-6 7/8"	1731
109'-10"	H	49.93	8.5	5.63	5'-6 7/8"	1852
150'-11"	J	63.7	16.69	5.63	7'-10 1/2"	2094

Load (ton)	Class
4	ASME H4+
5	H4

Headroom - C dimension	
Standard	14"
with HS22 Hook operated limit switch	16"

Note: Brake mounted to gearcase for Length code H & J
 Standard rail gauges are 3'-11 1/4", 4'-7 1/8", 5'-6 7/8", 6'-6 3/4", and 7'-10 1/2"
 Approx weight calculated with P5 motor and Min R
 M2 calculated with Min R.

This document is the absolute property of R&M Materials Handling, Inc. This document must not be copied without the written permission of R&M Materials Handling, Inc. The contents thereof must not be disclosed to a third party nor be used for any unauthorized purpose. Contravention will be prosecuted.

ETTPAL Design	ETTPAL Chd	Appd	Ref Drawing	QC-H-22
2002-08-29 Date	TROLLEY; DOUBLE GIRDER			1:12
SLEQDQCV Owner Dept	HIGH, 2x2 ROPE FALLS			Folder
R&M MATERIALS HANDLING INC.	R&M MATERIALS HANDLING, INC HOIST & CRANE PRODUCTS SPRINGFIELD, OHIO	D007182-A		Issue 4