

DOUBLE GIRDER, HIGH CLEARANCE, 4 PART DOUBLE
Hoist type:
SX5 042...DH

SI-60Hz

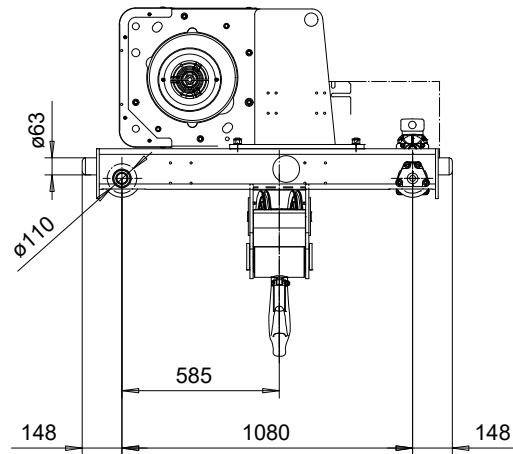
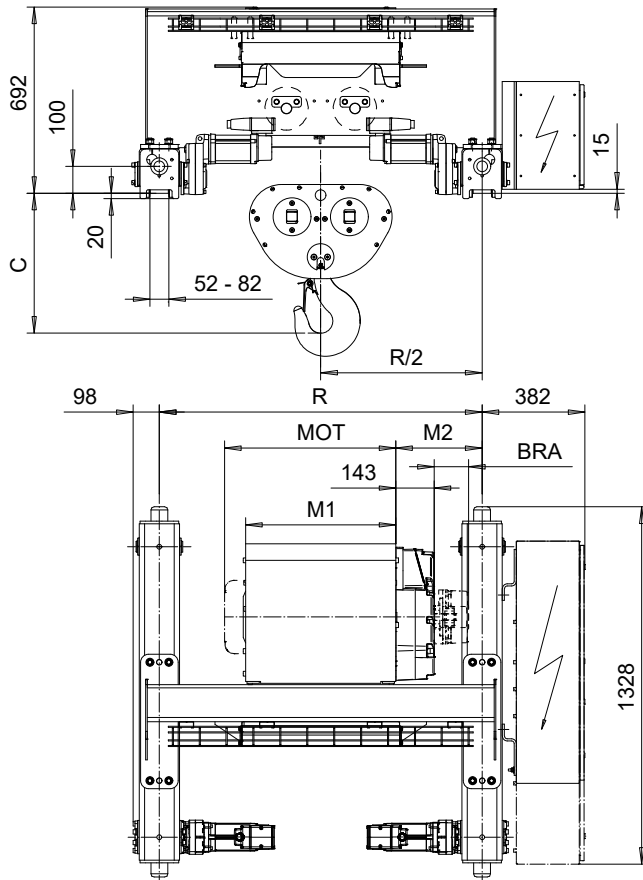

Motor	P5	P6	P7	A5	S5	S7
MOT (mm)	578	578	618	498	606	757
Weight (kg)	58	85	105	45	53	81

HOL	Length	M1	M2	BRA	Min R	Approx Weight
(m)	code	(mm)	(mm)	(mm)	(mm)	(kg)
4	D	558	321	-	1200	740
6.5	E	678	261	-	1200	760
9	F	828	286	-	1400	800
12.5	G	1018	341	-	1700	850
16.5	H	1268	216	128	1700	905
23	J	1618	424	128	2400	1015

Load	Class
(kg)	Fem/ISO
5000	3m/M6
6300	3m/M6
8000	3m/M6
10000	2m/M5

Headroom - C dimension	
Standard	520 mm
with HS22 Hook operated limit switch	570 mm

Note: Brake mounted to gearcase for Length code H & J
 Standard rail gauges are 1200, 1400, 1700, 2000, and 2400 mm
 Approx weight calculated with P5 motor and Min R
 M2 calculated with Min R.

This document is the absolute property of R&M Materials Handling, Inc. This document must not be copied without the written permission of R&M Materials Handling, Inc. The contents thereof must not be disclosed to a third party nor be used for any unauthorized purpose. Contravention will be prosecuted.

ETTPAL Design	ETTPAL Chd	Appd	Ref Drawing	QC-H-24
2002-08-29 Date	TROLLEY; DOUBLE GIRDER			1:12
SLEQDQCV Owner Dept	HIGH, 2x4 ROPE FALLS			Folder
R&M MATERIALS HANDLING INC.	R&M MATERIALS HANDLING, INC. HOIST & CRANE PRODUCTS SPRINGFIELD, OHIO	D007183-A		Issue 4