

DOUBLE GIRDER, ADJUSTABLE LOAD BEAM, 6 PART SINGLE
 Hoist type:
 SX5 061...D0

SI-50Hz

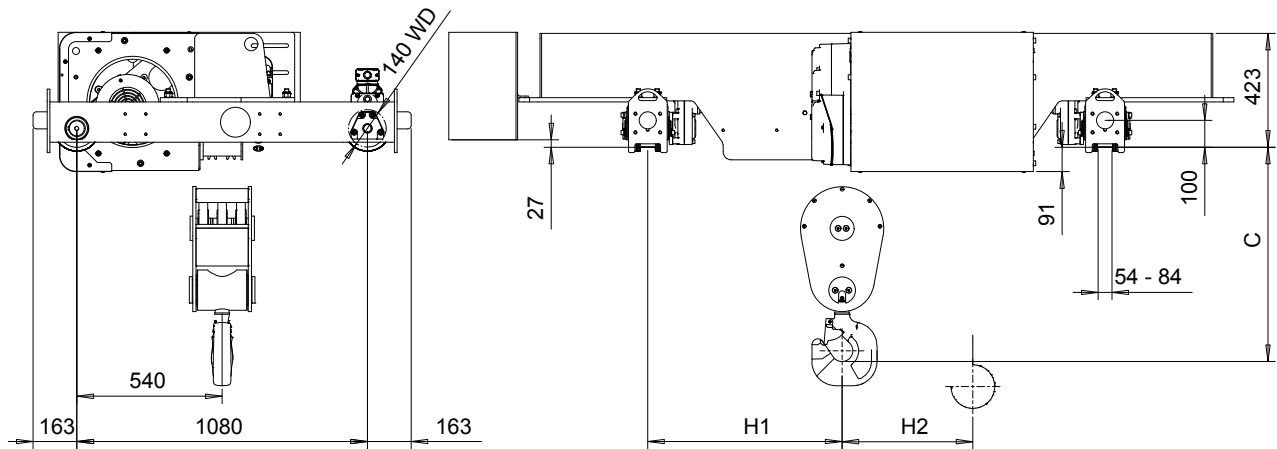

Motor	P5	P6	P7	A5	S5	S7
MOT (mm)	578	578	618	498	606	757
Weight (kg)	58	85	105	45	53	81

Load (kg)	Class Fem/ISO
12000	3m/M6
15000	2m/M5

HOL (m)	Length code	M1 (mm)	M2 (mm)	H1 (mm)	H2 (mm)	TW (mm)	Min R (mm)	Max R (mm)	Approx Weight (kg)
6	D	558	758	725	53	2658	1700	2438	895
8	E	678	758	725	78	2658	1700	2438	895
10	F	828	913	880	98	2658	2000	2438	910

Headroom - C dimension	
Standard	790 mm
with HS22 Hook operated limit switch	840 mm

Note: H1 and M2 are calculated from Min R.
 Special rail gauges
 Approx weight calculated with P5 motor

This document is the absolute property of R&M Materials Handling, Inc. This document must not be copied without the written permission of R&M Materials Handling, Inc. The contents thereof must not be disclosed to a third party nor be used for any unauthorized purpose. Contravention will be prosecuted.

ETTPAL Design	ETTPAL Chd	Appd	Ref Drawing	QC-ALB-06
2018-10-01 Date	TROLLEY; DOUBLE GIRDER			1:12
SLEQDQCV Owner Dept	ADJUSTABLE LOAD BEAM, 6 ROPE FALLS			Folder
R&M MATERIALS HANDLING INC.	R&M MATERIALS HANDLING, INC HOIST & CRANE PRODUCTS SPRINGFIELD, OHIO	55279565-vxp1-1		Issue 1