

DOUBLE GIRDER, ADJUSTABLE LOAD BEAM, 8 PART SINGLE  
 Hoist type:  
 SX5 081...D0

SI-50Hz

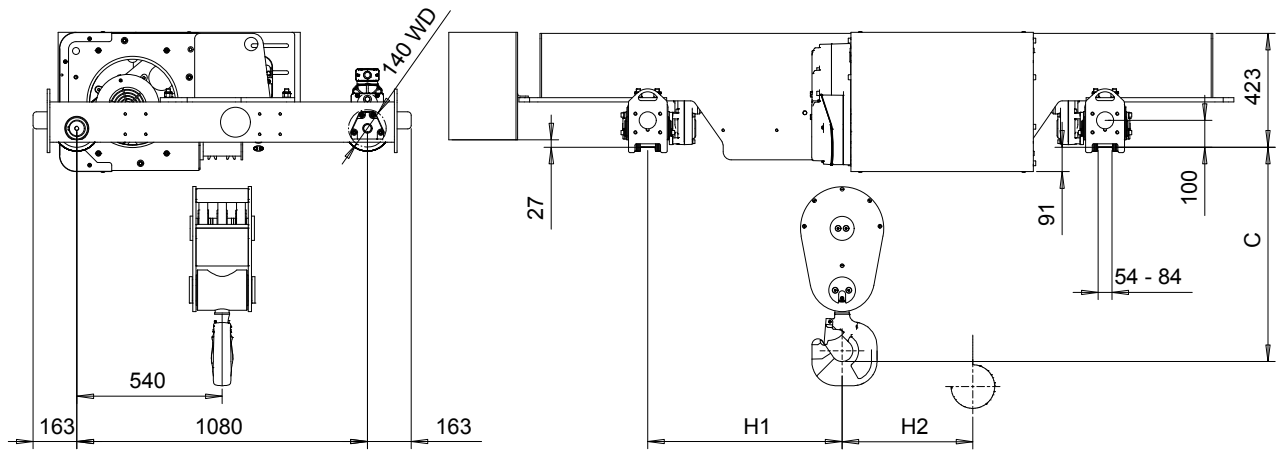

Motor	P5	P6	P7	A5	S5	S7
MOT (mm)	578	578	618	498	606	757
Weight (kg)	58	85	105	45	53	81

Load (kg)	Class Fem/ISO
16000	2m/M5
20000	1Am/M4

HOL (m)	Length code	M1 (mm)	M2 (mm)	H1 (mm)	H2 (mm)	TW (mm)	Min R (mm)	Max R (mm)	Approx Weight (kg)
4.5	D	558	758	725	44	2658	1700	2438	895
6	E	678	758	725	59	2658	1700	2438	895
8	F	828	913	880	77	2658	2000	2438	910

Headroom - C dimension	
Standard	790 mm
with HS22 Hook operated limit switch	840 mm

Note: H1 and M2 are calculated from Min R.  
 Special rail gauges  
 Approx weight calculated with P5 motor

This document is the absolute property of R&M Materials Handling, Inc. This document must not be copied without the written permission of R&M Materials Handling, Inc. The contents thereof must not be disclosed to a third party nor be used for any unauthorized purpose. Contravention will be prosecuted.

ETPAL Design	ETPAL Chd	Appd	Ref Drawing	QC-ALB-08
2018-10-01 Date	TROLLEY; DOUBLE GIRDER			1:12
SLEQDQCV Owner Dept	ADJUSTABLE LOAD BEAM, 6 ROPE FALLS			Folder
R&M MATERIALS HANDLING INC.	R&M MATERIALS HANDLING, INC HOIST & CRANE PRODUCTS SPRINGFIELD, OHIO	55288360-vxp1-1		Issue 1