

DOUBLE GIRDER, ADJUSTABLE LOAD BEAM, 8 PART SINGLE  
 Hoist type:  
 SX5 081...D0

US-60Hz

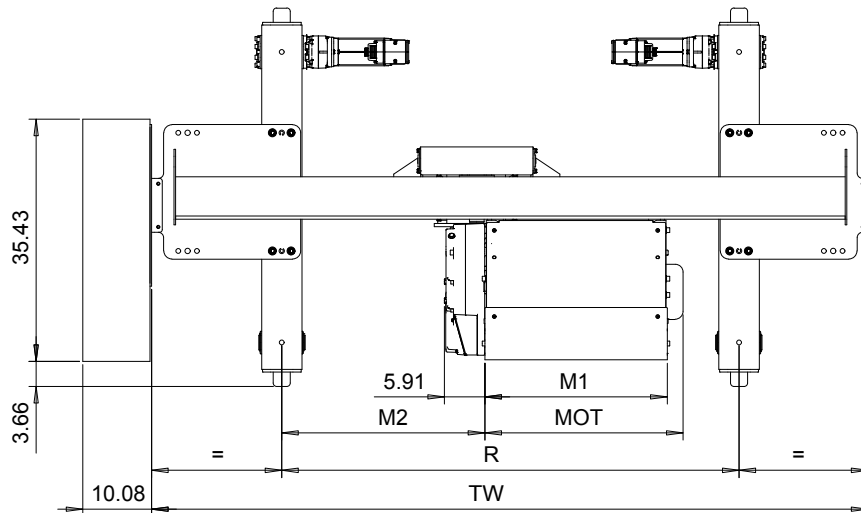
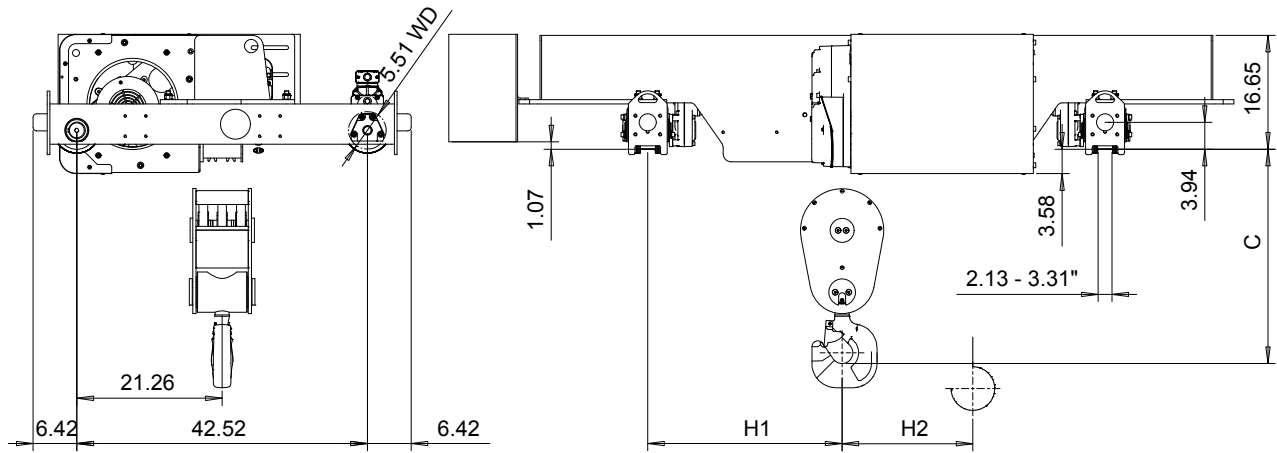

| Motor       | P5    | P6    | P7    | A5    | S5    | S7   |
|-------------|-------|-------|-------|-------|-------|------|
| MOT (in)    | 22.76 | 22.76 | 24.33 | 19.61 | 23.86 | 29.8 |
| Weight (lb) | 128   | 187   | 231   | 99    | 117   | 179  |

| Load (ton) | Class ASME |
|------------|------------|
| 15         | H4         |
| 20         | H3         |

| HOL (ft) | Length code | M1 (inch) | M2 (inch) | H1 (inch) | H2 (inch) | TW (inch) | Min R       | Max R | Approx Weight (lb) |
|----------|-------------|-----------|-----------|-----------|-----------|-----------|-------------|-------|--------------------|
| 14'-9"   | D           | 21.97     | 29.84     | 28.54     | 1.73      | 104.65    | 5'-6 15/16" | 8'-0" | 1973               |
| 19'-8"   | E           | 26.69     | 29.84     | 28.54     | 2.09      | 104.65    | 5'-6 15/16" | 8'-0" | 1973               |
| 26'-2"   | F           | 32.6      | 35.94     | 34.65     | 2.99      | 104.65    | 6'-6 3/4"   | 8'-0" | 2007               |

| Headroom - C dimension               |       |
|--------------------------------------|-------|
| Standard                             | 31.1" |
| with HS22 Hook operated limit switch | 33.1" |

Note: H1 and M2 are calculated from Min R.  
 Special rail gauges  
 Approx weight calculated with P5 motor

This document is the absolute property of R&M Materials Handling, Inc. This document must not be copied without the written permission of R&M Materials Handling, Inc. The contents thereof must not be disclosed to a third party nor be used for any unauthorized purpose. Contravention will be prosecuted.

|                             |   |                 |             |           |
|-----------------------------|---|-----------------|-------------|-----------|
| ETTPAL Design               | ETTPAL Chd  | Appd            | Ref Drawing | QC-ALB-08 |
| 2018-10-01 Date             | TROLLEY; DOUBLE GIRDER  |                 |             | 1:12      |
| SLEQDQCV Owner Dept         | ADJUSTABLE LOAD BEAM, 6 ROPE FALLS                                    |                 |             | Folder    |
| R&M MATERIALS HANDLING INC. | R&M MATERIALS HANDLING, INC. HOIST & CRANE PRODUCTS SPRINGFIELD, OHIO | 55288360-vxp1-1 |             | Issue 1   |