

Double Girder Hoist EXSX5, REEVING: 021; Class I, Division 2

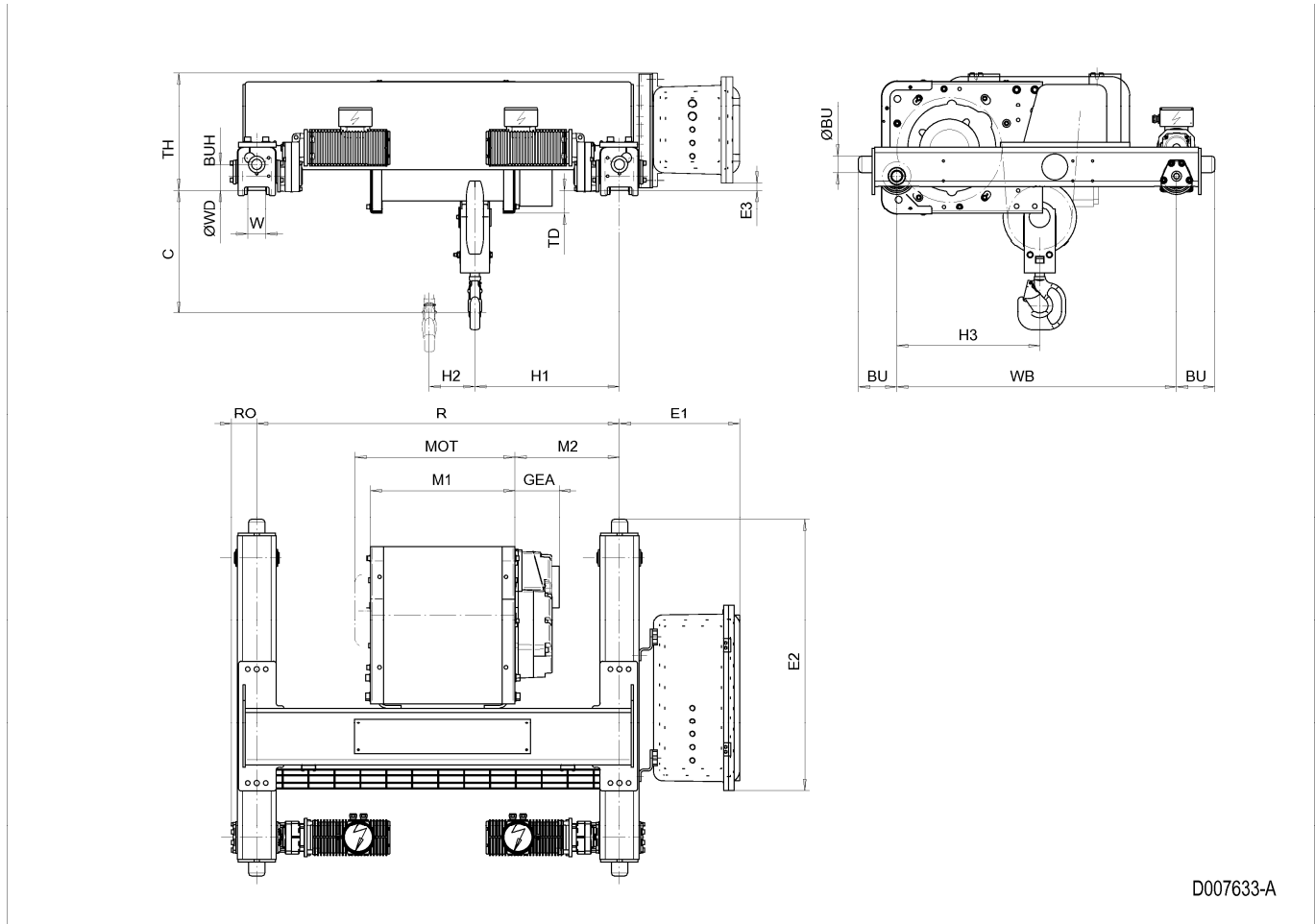

D007633-A

Hoist dimensions

HOL m	Length code	M1 mm	M2 mm	H1 mm	H2 mm	Min R mm	Weight kg
18	D	558	259	558	176	1400	956
24	E	678	259	558	235	1400	997
32	F	828	372	671	309	1700	1054
40	G	1018	522	821	403	2000	1125

Motor dimensions

Motor	P5	P6
MOT (mm)	578	578
Weight (kg)	58	85

Trolley dimensions

C	ØBU	ØWD	WB	W min	W max	BU	BUH	E1	E2	E3	GEA
520	63	110	1080	52	87	148	100	463.8	1046.7	28.1	170
H3	RO	TD	TH								
552	98	98	455.1								

D007633_A
252849

Note: Weight calculated with P5 motor.

Note: All dimensions in mm.

Note: Min R with service platform.

Note: Standard rail gauges: 1400, 1700 and 2000.

Note: Flangeless wheels available.