

Double Girder Hoist EXSX5, REEVING: 021; Class I, Division 2

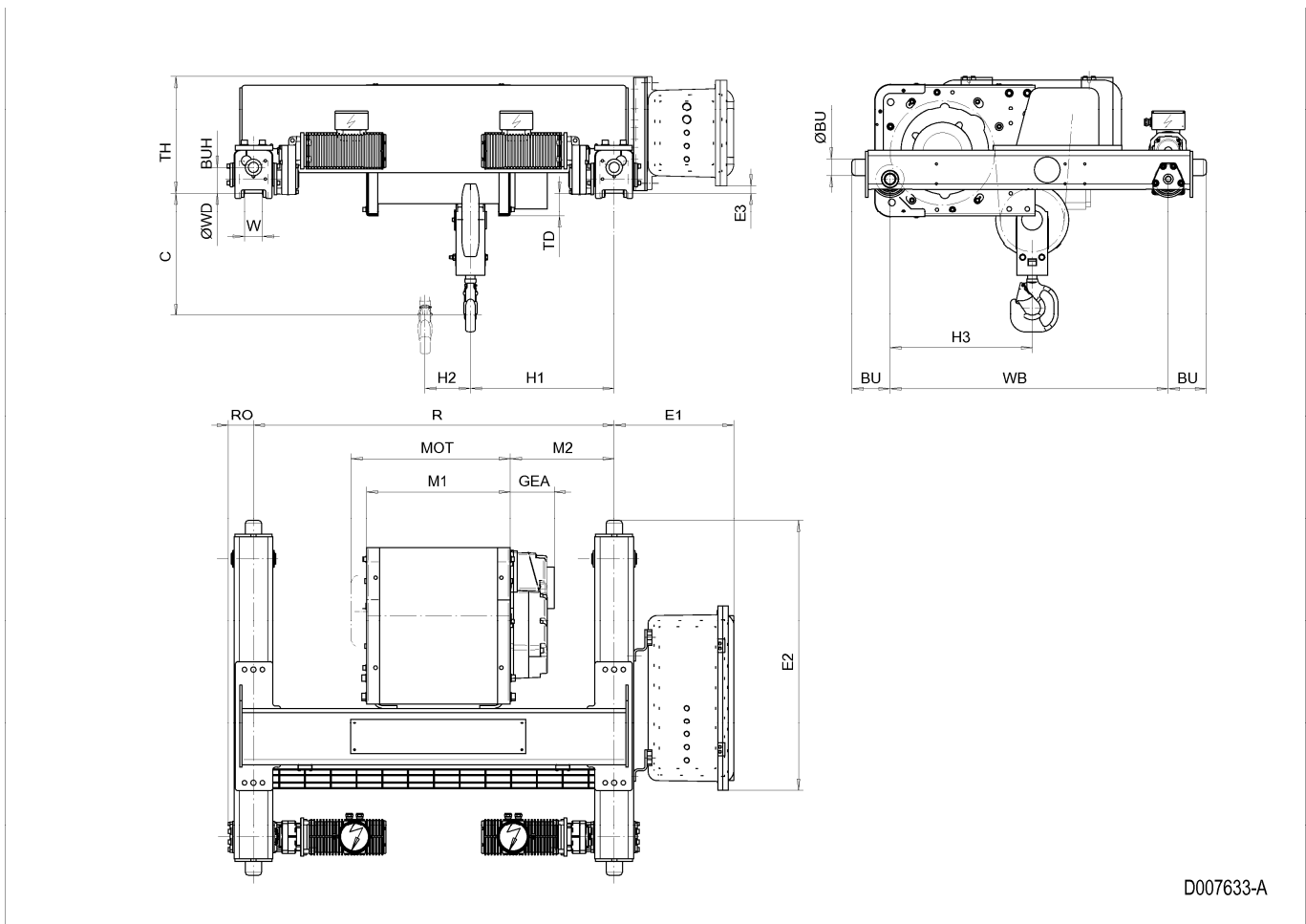

D007633-A

**Hoist dimensions**

HOL ft	Length code	M1 inch	M2 inch	H1 inch	H2 inch	Min R inch	Weight lb
59'-1"	D	21.97	10.2	21.97	6.93	55.12	2108
78'-9"	E	26.69	10.2	21.97	9.25	55.12	2198
104'-12"	F	32.6	14.65	26.42	12.17	66.93	2324
131'-3"	G	40.08	20.55	32.32	15.87	78.74	2481

**Motor dimensions**

Motor	P5	P6
MOT (inch)	22.76	22.76
Weight (lb)	128	187

**Trolley dimensions**

C	ØBU	ØWD	WB	W min	W max	BU	BUH	E1	E2	E3	GEA
20.47	2.48	4.33	42.52	2.05	3.43	5.83	3.94	18.26	41.21	1.11	6.69
H3	RO	TD	TH								
21.73	3.86	3.86	17.92								

D007633\_A  
252849

- Note: Weight calculated with P5 motor.
- Note: All dimensions in inch.
- Note: Min R with service platform.
- Note: Standard rail gauges: 55.1, 66.9 and 78.7.
- Note: Flangeless wheels available.