

Double Girder Hoist EXSX5, REEVING: 022; Class I, Division 2

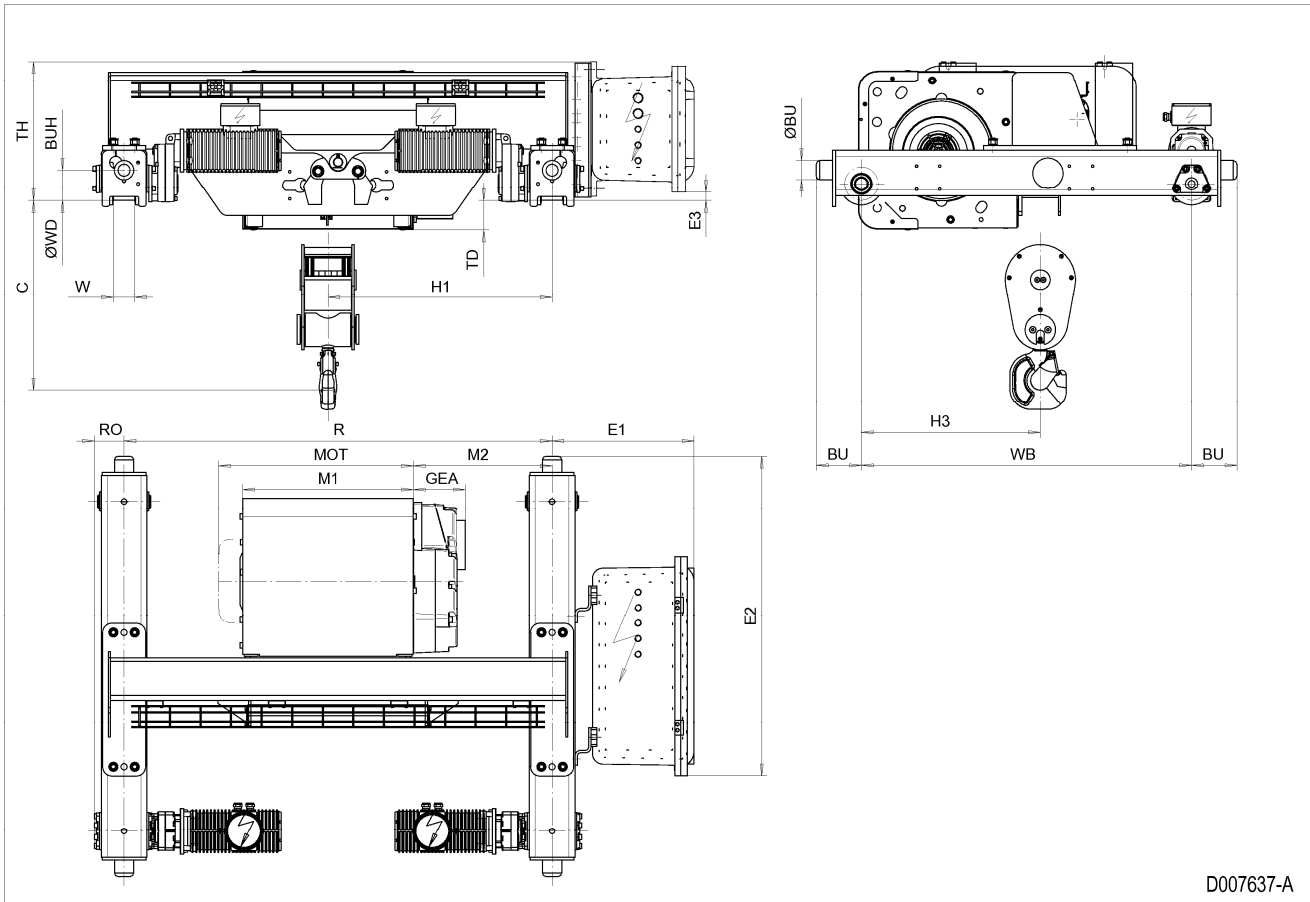

D007637-A

Hoist dimensions

HOL m	Length code	H1 mm	M1 mm	M2 mm	Min R mm	Weight kg
8.5	D	733	558	454	1400	908
13	E	733	678	394	1400	933
18	F	883	828	469	1700	988
25	G	883	1018	374	1700	1028
33.5	H	1033	1268	399	2000	1104
46	J	1233	1618	424	2400	1205

Motor dimensions

Motor	P5	P6
MOT (mm)	578	578
Weight (kg)	58	85

Trolley dimensions

C	ØBU	BU	BUH	E1	E2	E3	GEA	H3	WB	ØWD	W min
620	63	148	100	463.8	1046.7	28.1	170	585	1080	110	52
W max	RO	TD	TH								
87	98	97	455.1								

D007637_A
252854

Note: All dimensions in mm.

Note: Weight calculated with P5 motor.

Note: Min R with service platform.

Note: Standard rail gauges: 1400, 1700, 2000 and 2400.

Note: H1, M2 and weight calculated with Min R.

Note: Flangeless wheels available.