

Double Girder Hoist EXSX5, REEVING: 022; Class I, Division 2

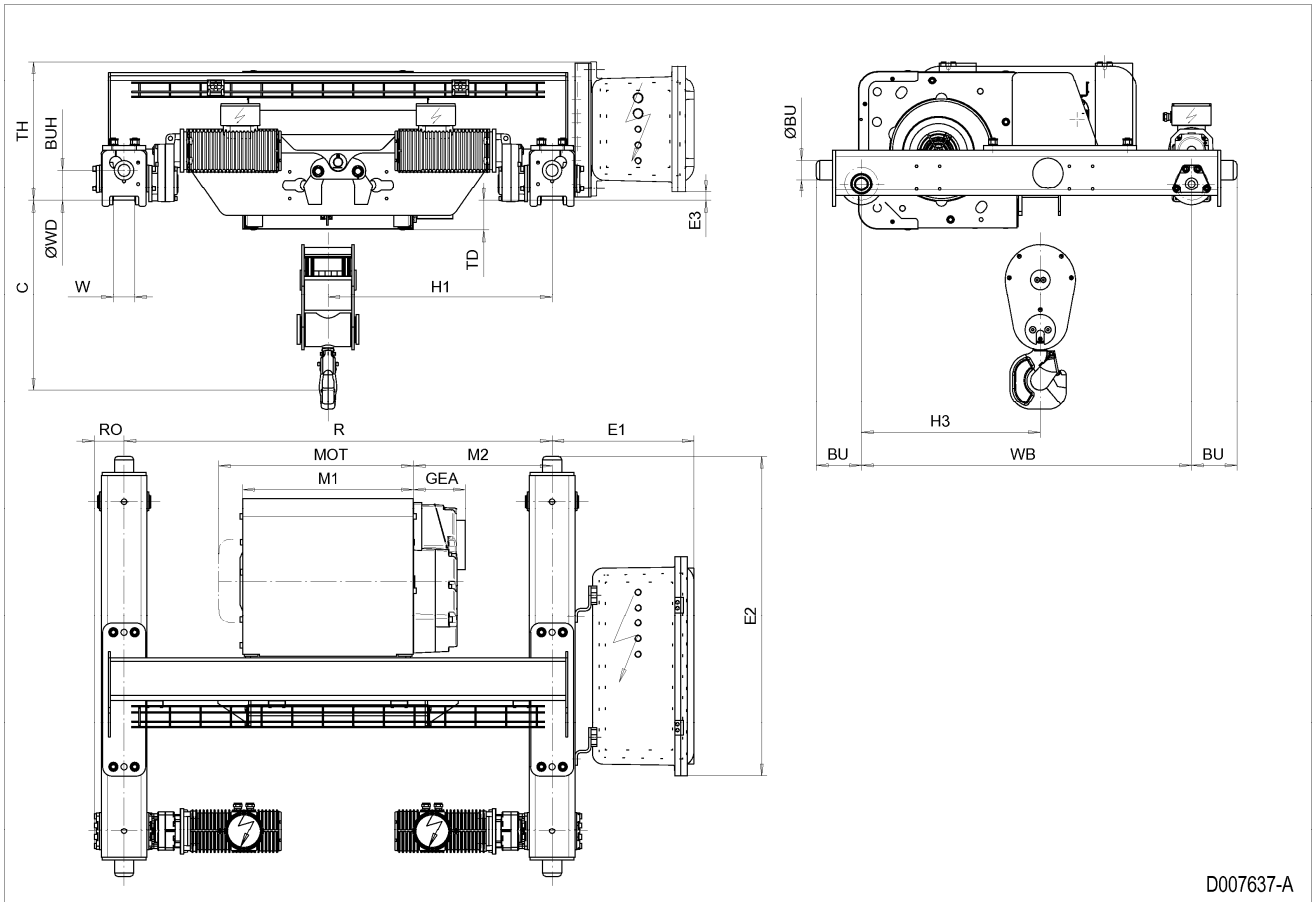

D007637-A

Hoist dimensions

HOL ft	Length code	H1 inch	M1 inch	M2 inch	Min R inch	Weight lb
27'-11"	D	28.86	21.97	17.87	55.12	2002
42'-8"	E	28.86	26.69	15.51	55.12	2057
59'-1"	F	34.76	32.6	18.46	66.93	2179
82'-0"	G	34.76	40.08	14.72	66.93	2267
109'-11"	H	40.67	49.92	15.71	78.74	2434
150'-11"	J	48.54	63.7	16.69	94.49	2657

Motor dimensions

Motor	P5	P6
MOT (inch)	22.76	22.76
Weight (lb)	128	187

Trolley dimensions

C	ØBU	BU	BUH	E1	E2	E3	GEA	H3	WB	ØWD	W min
24.41	2.48	5.83	3.94	18.26	41.21	1.11	6.69	23.03	42.52	4.33	2.05
W max	RO	TD	TH								
3.43	3.86	3.82	17.92								

D007637_A
252854

Note: All dimensions in inch.

Note: Weight calculated with P5 motor.

Note: Min R with service platform.

Note: Standard rail gauges: 55.1, 66.9, 78.7 and 94.5.

Note: H1, M2 and weight calculated with Min R.

Note: Flangeless wheels available.