

Fixed Hoist EXSX5, REEVING: 022; Class I, Division 2

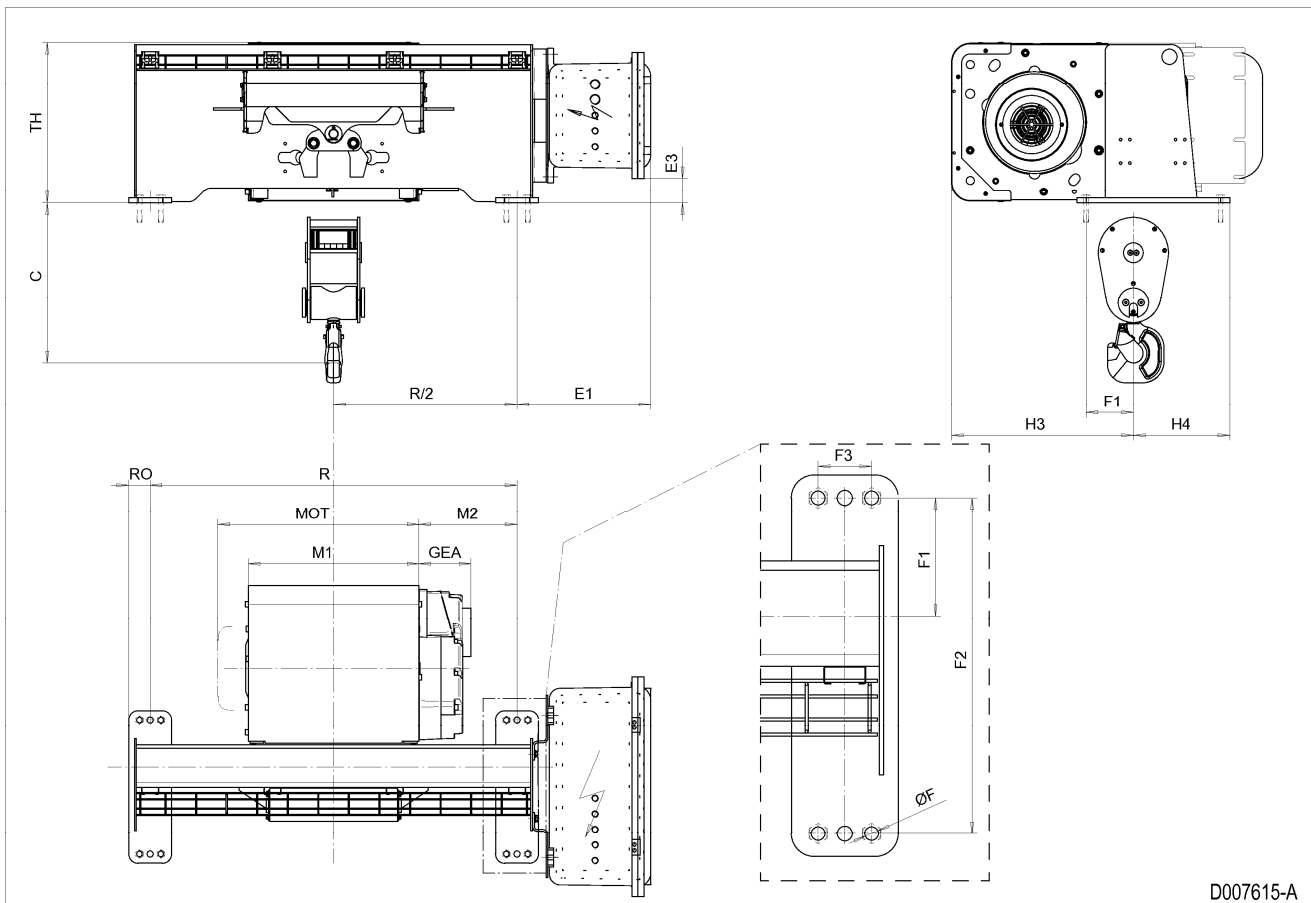

D007615-A

**Hoist dimensions**

HOL m	Length code	M1 mm	M2 mm	Min R mm	H3 mm	H3* mm	Weight kg
8.5	D	558	321	1200	595	615	742
13	E	678	261	1200	595	615	767
18	F	828	186	1200	595	615	799
25	G	1018	91	1200	595	615	880
33.5	H	1268	216	1700	595	615	928
46	J	1618	191	2000	595	615	1023

**Motor dimensions**

Motor	P5	P6
MOT (mm)	578	578
Weight (kg)	58	85

**Trolley dimensions**

C	ØF	E1	E3	F1	F2	F3	GEA	H4	RO	TH	
523	18	437.6	81	155	440	70	170	315	70	527.1	

D007615\_A  
252820

Note: All dimensions in mm.

Note: Weight calculated with P5 motor.

Note: M2 and weight calculated with Min R.

Note: Standard rail gauges: 1200, 1700 and 2000.

\* Please, disregard the dimension H3\*.