

Normal Headroom Hoist EXSX5, REEVING: 022; Class I, Division 2

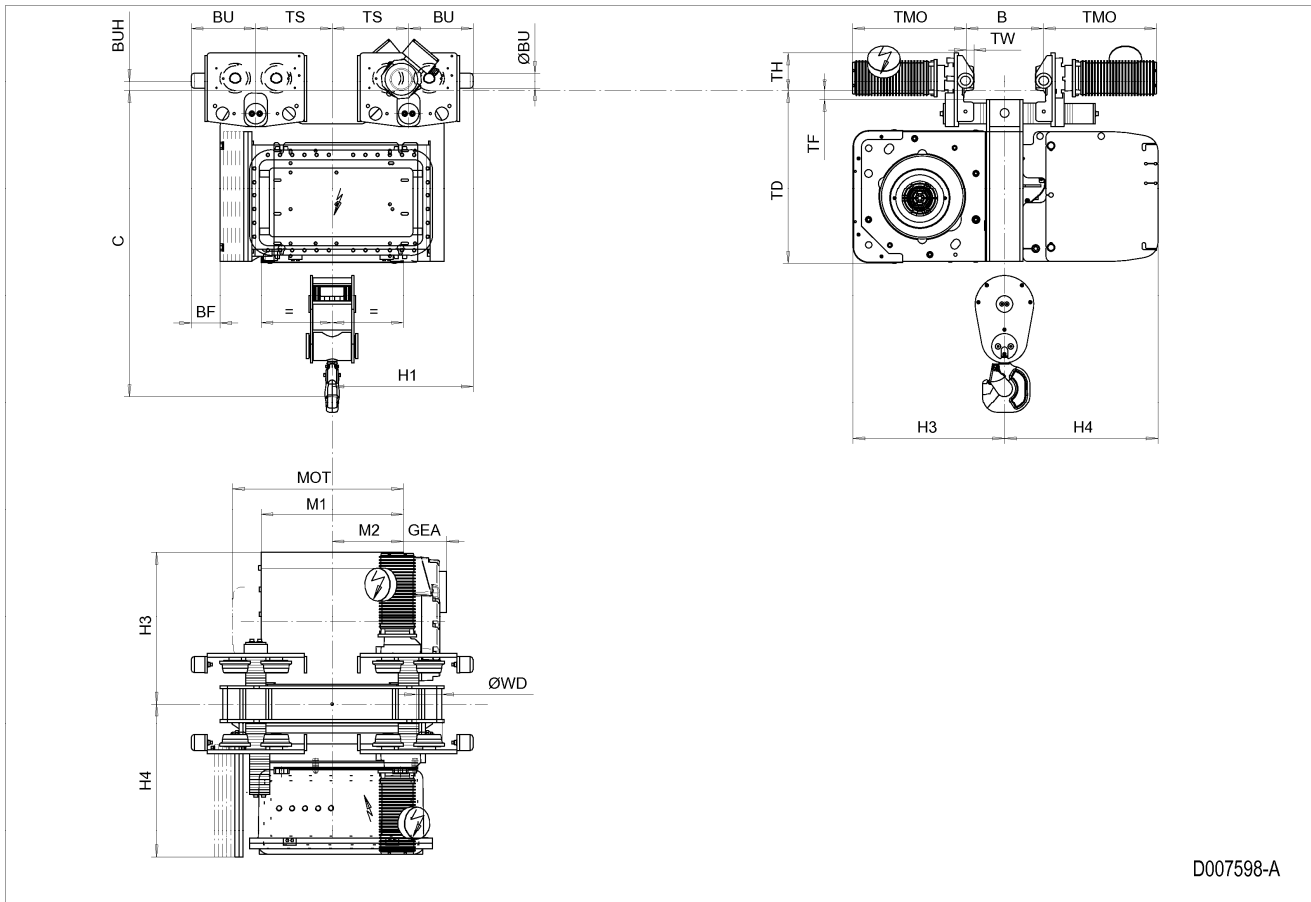

Hoist dimensions

HOL m	Length code	M1 mm	M2 mm	H1 mm	H3 mm	H3* mm	H4 mm	Weight kg
8.5	D	558	279	553	595	615	602	899
13	E	678	339	553	595	615	602	924
18	F	828	414	553	595	615	602	955
25	G	1018	509	753	595	615	602	1083
33.5	H	1268	634	753	595	615	602	1192
46	J	1618	809	753	595	615	602	1293

Motor dimensions

Motor	P5	P6	E4	E6
MOT (mm)	578	578	683	683
Weight (kg)	58	85	145	145

Traveling dimensions

Motor	MF06LA
TMO (mm)	400
Weight (kg)	7.8

Trolley dimensions

B min	B max	C	\varnothing BU	\varnothing WD	BU	BUH	GEA	TD	TF	TH	TW
90	610	1200	63	100	253	40	170	676	35	150	33

Trolley dimensions

Length code	BF	TS
D/E/F	113	300
G/H/J	-77	500

D007598_A
252286

Note: Weight calculated with P5 and MF06LA motors, when B=300 mm.

Note: All dimensions in mm.

* Please, disregard the dimension H3*.