

Fixed Hoist EXSX5, REEVING: 041; Class I, Division 2

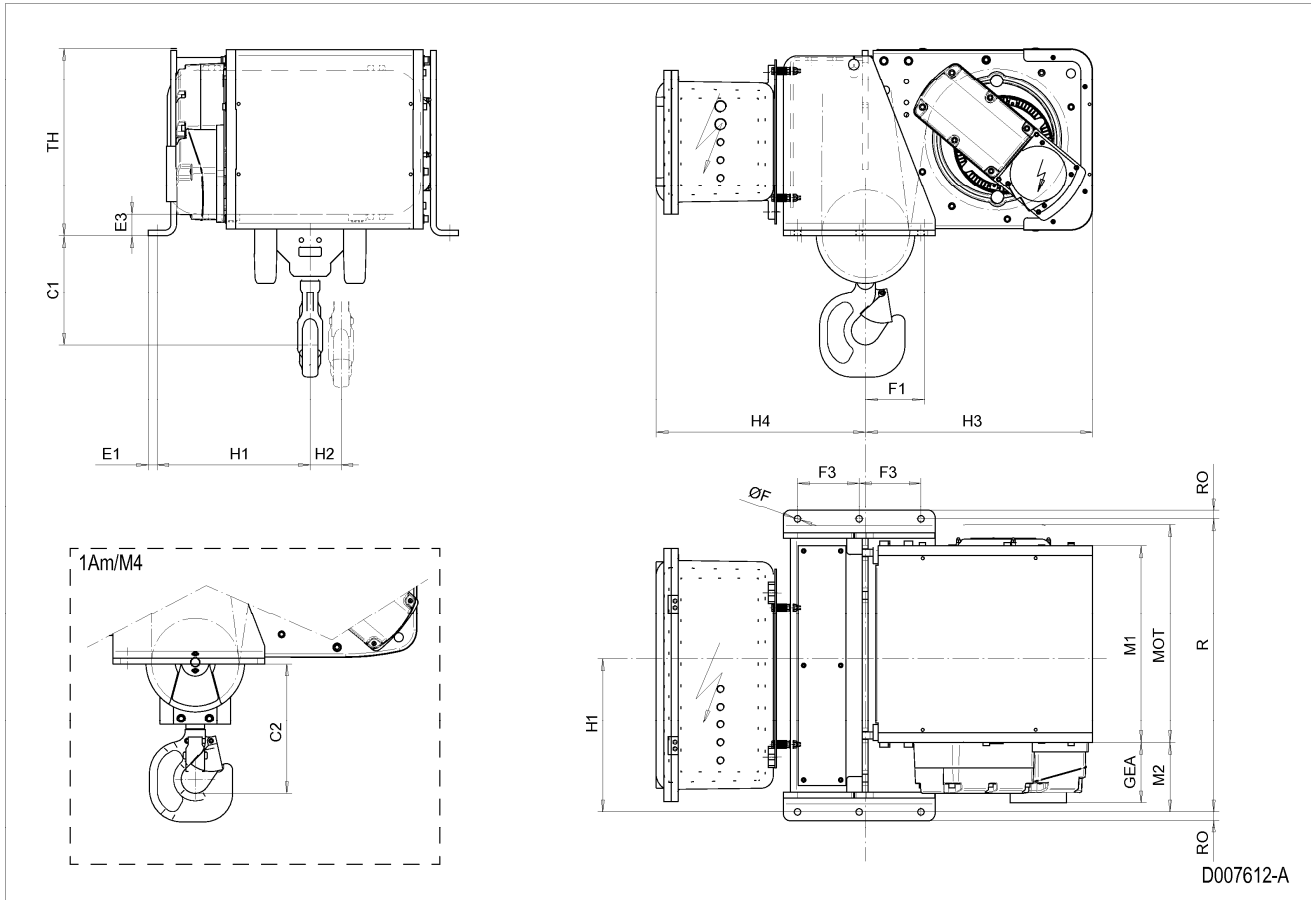

D007612-A

**Hoist dimensions**

HOL ft	Length code	M1 inch	M2 inch	H1 inch	H2 inch	H3 inch	H3* inch	R inch	Weight lb
29'-6"	D	21.97	7.72	17.09	3.46	25.39	26.18	32.68	1641
39'-4"	E	26.69	2.99	12.36	4.65	25.39	26.18	32.68	1715
52'-6"	F	32.6	2.99	12.36	6.14	25.39	26.18	46.06	1865
65'-7"	G	40.08	2.99	12.36	8.03	25.39	26.18	46.06	1954

**Motor dimensions**

Motor	P5	P6
MOT (inch)	22.76	22.76
Weight (lb)	128	187

**Trolley dimensions**

C1	C2	ØF	E1	E3	F1	F3	GEA	H4	RO	TH
12.2	14.45	0.71	0.98	2.41	6.61	6.89	6.69	26.14	0.98	21.09

D007612\_A  
252816

Note: All dimensions in inch.

Note: Weight calculated with P5 motor.

\* Please, disregard the dimension H3\*.