

Low Headroom Hoist EXSX5, REEVING: 041 Class I, Division 1

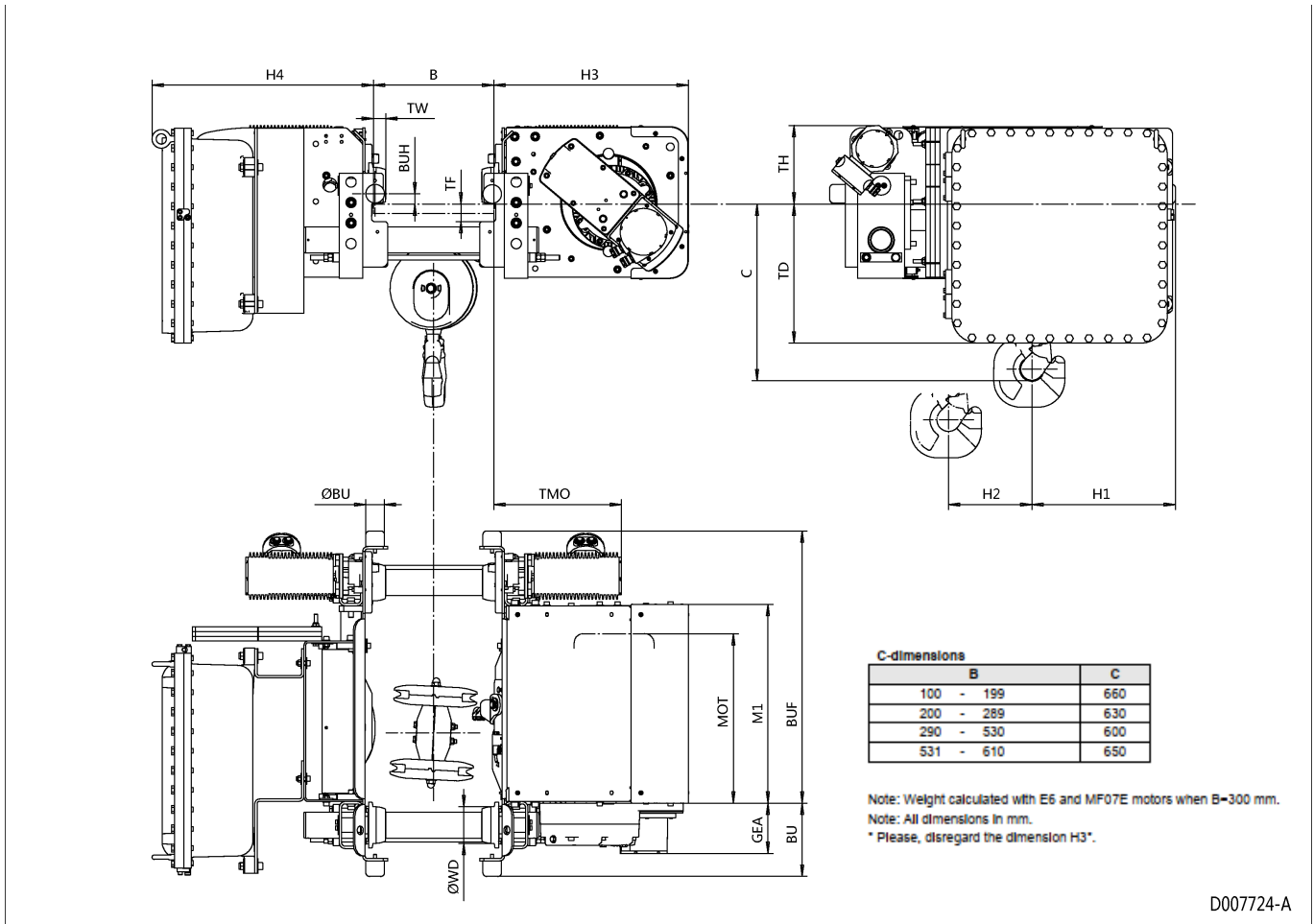

D007724-A

**Hoist dimensions**

| HOL<br>m | Length<br>code | M1<br>mm | H1<br>mm | H2<br>mm | H3<br>mm | H3*<br>mm | H4<br>mm | BUF<br>mm | Weight<br>kg |
|----------|----------------|----------|----------|----------|----------|-----------|----------|-----------|--------------|
| 12       | E              | 678      | 531      | 118      | 663      | 683       | 755      | 928       | 1060         |
| 16       | F              | 828      | 531      | 156      | 663      | 683       | 755      | 1078      | 1110         |

**Motor dimensions**

| Motor       | E4  | E6  |
|-------------|-----|-----|
| MOT (mm)    | 673 | 673 |
| Weight (kg) | 145 | 145 |

**Travelling dimensions**

| Motor       | MF07E |
|-------------|-------|
| TMO (mm)    | 435   |
| Weight (kg) | 13    |

**Trolley dimensions**

| B min. | B max. | ØBU | ØWD | BU  | BUH | GEA | TD  | TF | TH  | TW   |
|--------|--------|-----|-----|-----|-----|-----|-----|----|-----|------|
| 100    | 610    | 63  | 125 | 250 | 35  | 172 | 475 | 59 | 268 | 41.5 |

D007724-A  
314911