

Normal Headroom Hoist EXSX5, REEVING: 042; Class I, Division 2

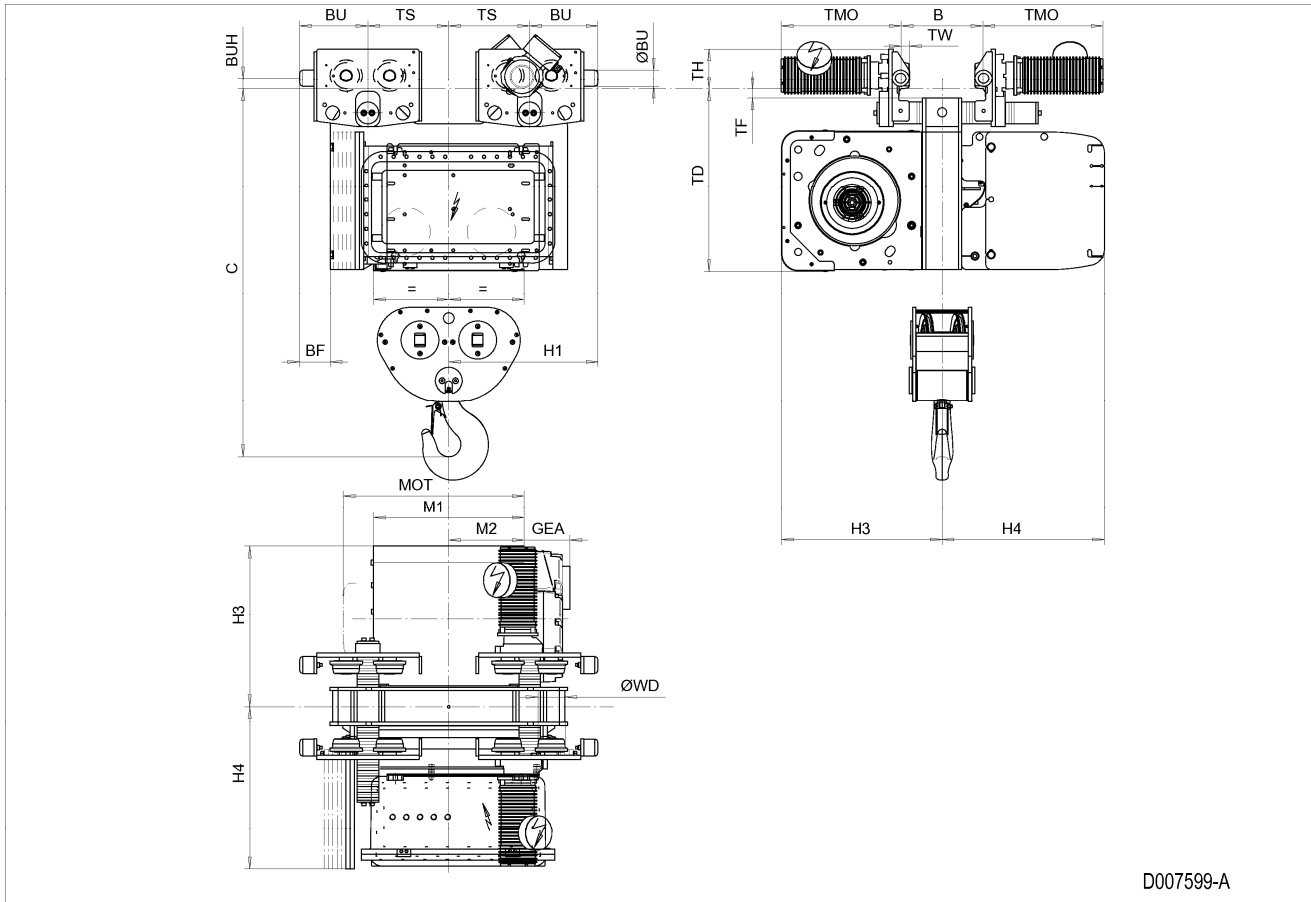

D007599-A

**Hoist dimensions**

HOL ft	Length code	M1 inch	M2 inch	H1 inch	H3 inch	H3* inch	H4 inch	Weight lb
13'-1"	D	21.97	10.98	21.77	23.43	24.21	23.7	2141
21'-4"	E	26.69	13.35	21.77	23.43	24.21	23.7	2196
29'-6"	F	32.6	16.3	21.77	23.43	24.21	23.7	2265
41'-0"	G	40.08	20.04	29.65	23.43	24.21	23.7	2547
54'-2"	H	49.92	24.96	29.65	23.43	24.21	23.7	2787
75'-6"	J	63.7	31.85	29.65	23.43	24.21	23.7	3010

**Motor dimensions**

Motor	P5	P6	E4	E6
MOT (inch)	22.76	22.76	26.89	26.89
Weight ( lb)	128	187	320	320

**Traveling dimensions**

Motor	MF06LA
TMO (inch)	15.75
Weight (lb)	17

**Trolley dimensions**

B min	B max	C	ØBU	ØWD	BU	BUH	GEA	TD	TF	TH	TW
3.54	24.02	53.74	2.48	3.94	9.96	1.57	6.69	26.61	1.38	5.91	1.22

**Trolley dimensions**

Length code	BF	TS
D/E/F	4.45	11.81
G/H/J	-3.03	19.69

D007599\_A  
252299

Note: Weight calculated with P5 and MF06LA motors, when B=11.8 inch.

Note: All dimensions in inch.

\* Please, disregard the dimension H3\*.