

Fixed Hoist EXSX5, REEVING: 062; Class I, Division 2

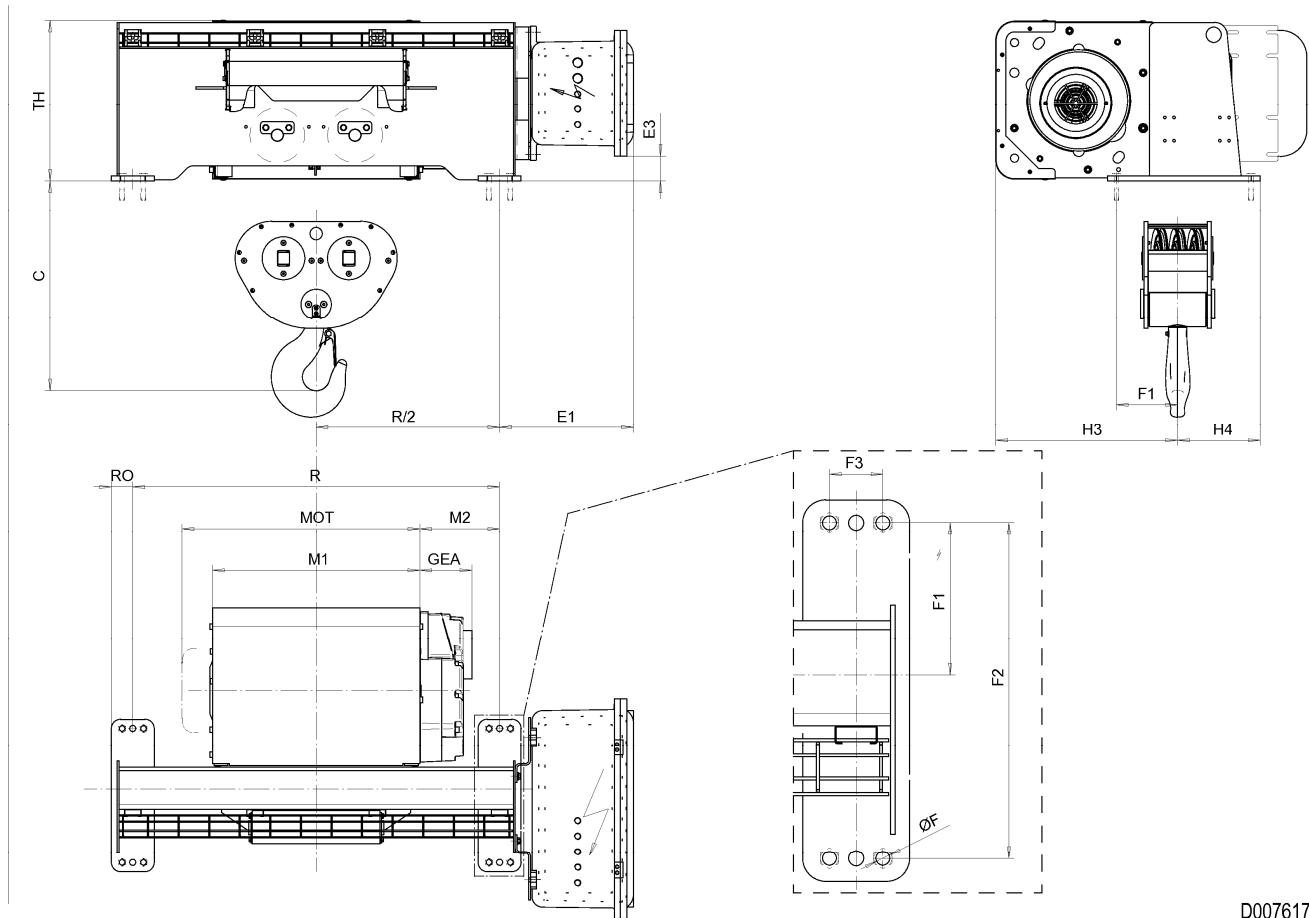

D007617-A

Hoist dimensions

HOL m	Length code	M1 mm	M2 mm	Min R mm	H3 mm	H3* mm	Weight kg
4	E	678	261	1200	595	615	847
6	F	828	186	1200	595	615	879
8	G	1018	91	1200	595	615	955
11	H	1268	216	1700	595	615	1009
15	J	1618	191	2000	595	615	1104

Motor dimensions

Motor	P5	P6
MOT (mm)	578	578
Weight (kg)	58	85

Trolley dimensions

C	ØF	E1	E3	F1	F2	F3	GEA	H4	RO	TH
688	18	437.6	81.1	200	440	70	170	270	70	527.1

D007617_A
252822

Note: All dimensions in mm.

Note: Weight calculated with P5 motor.

Note: M2 and weight calculated with Min R.

Note: Standard rail gauges: 1200, 1700 and 2000.

* Please, disregard the dimension H3*.