

Normal Headroom Hoist EXSX5, REEVING: 081; Class I, Division 2

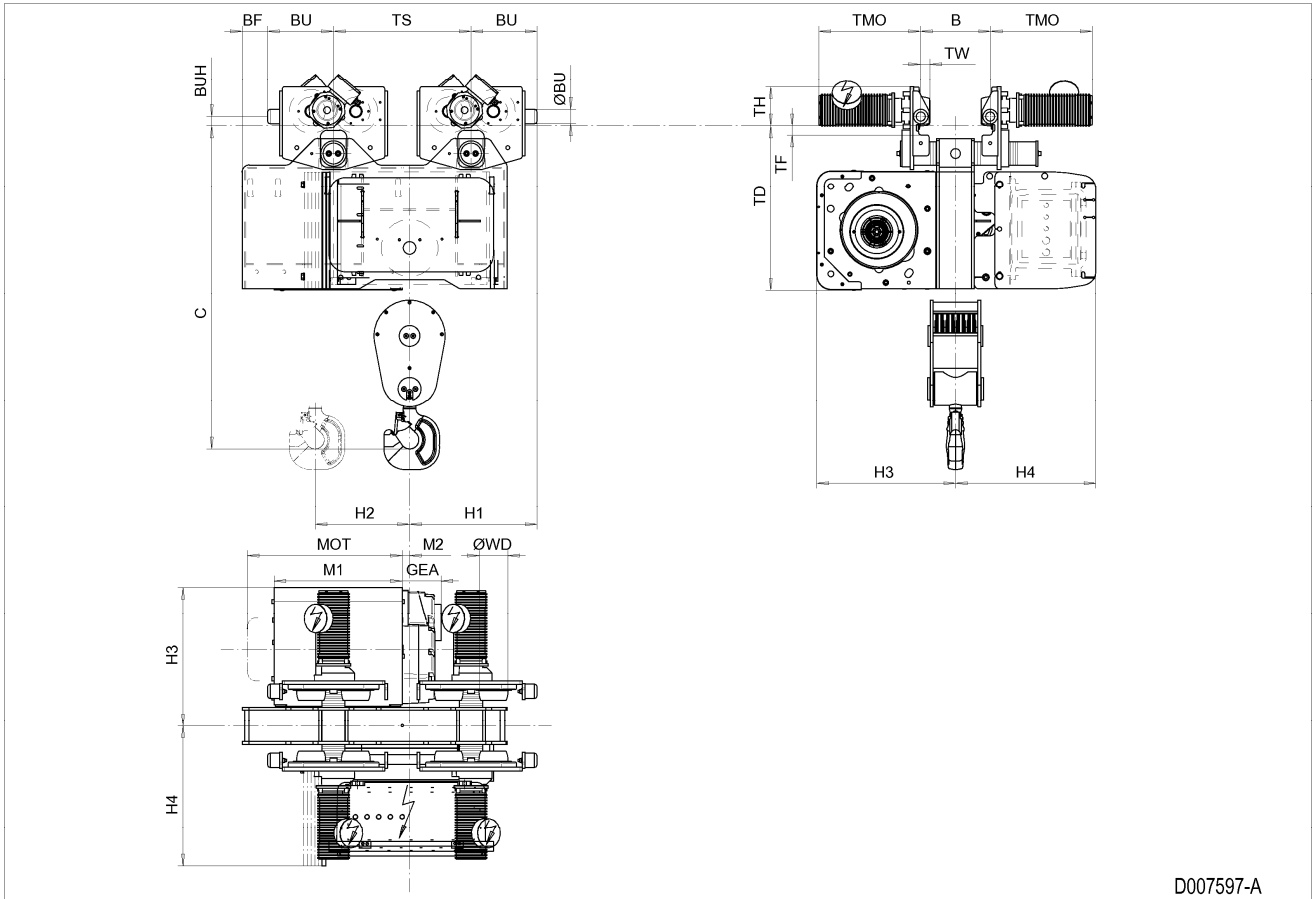

**Hoist dimensions**

HOL ft	Length code	M1 inch	M2 inch	H1 inch	H2 inch	H3 inch	H3* inch	H4 inch	Weight lb
14'-9"	D	21.97	1.3	21.89	1.73	23.82	24.61	24.09	2470
19'-8"	E	26.69	1.3	21.89	2.09	23.82	24.61	24.09	2525
26'-3"	F	32.6	1.3	23.46	2.99	23.82	24.61	24.09	2683
32'-10"	G	40.08	1.3	23.46	3.86	23.82	24.61	24.09	2772

**Motor dimensions**

Motor	P5	P6	E4	E6
MOT (inch)	22.76	22.76	26.89	26.89
Weight ( lb)	128	187	320	320

**Traveling dimensions**

Motor	MF06LA
TMO (inch)	15.67
Weight (lb)	17

**Trolley dimensions**

B min	B max	C	ØBU	ØWD	BU	BUH	GEA	TF	TD	TH	TW
4.33	24.02	55.63	2.48	4.92	11.34	1.57	6.69	1.56	28.19	6.69	1.63

**Trolley dimensions**

Length code	BF	TS
D/E	4.33	23.62
F/G	14.57	28.35

D007597\_A  
252284

Note: All dimensions in inch.

Note: Weight calculated with P5 and MF06LA motors, when B=11.8 inch.

\* Please, disregard the dimension H3\*.