

Normal Headroom Hoist EXSX6, REEVING: 022; Class I, Division 2

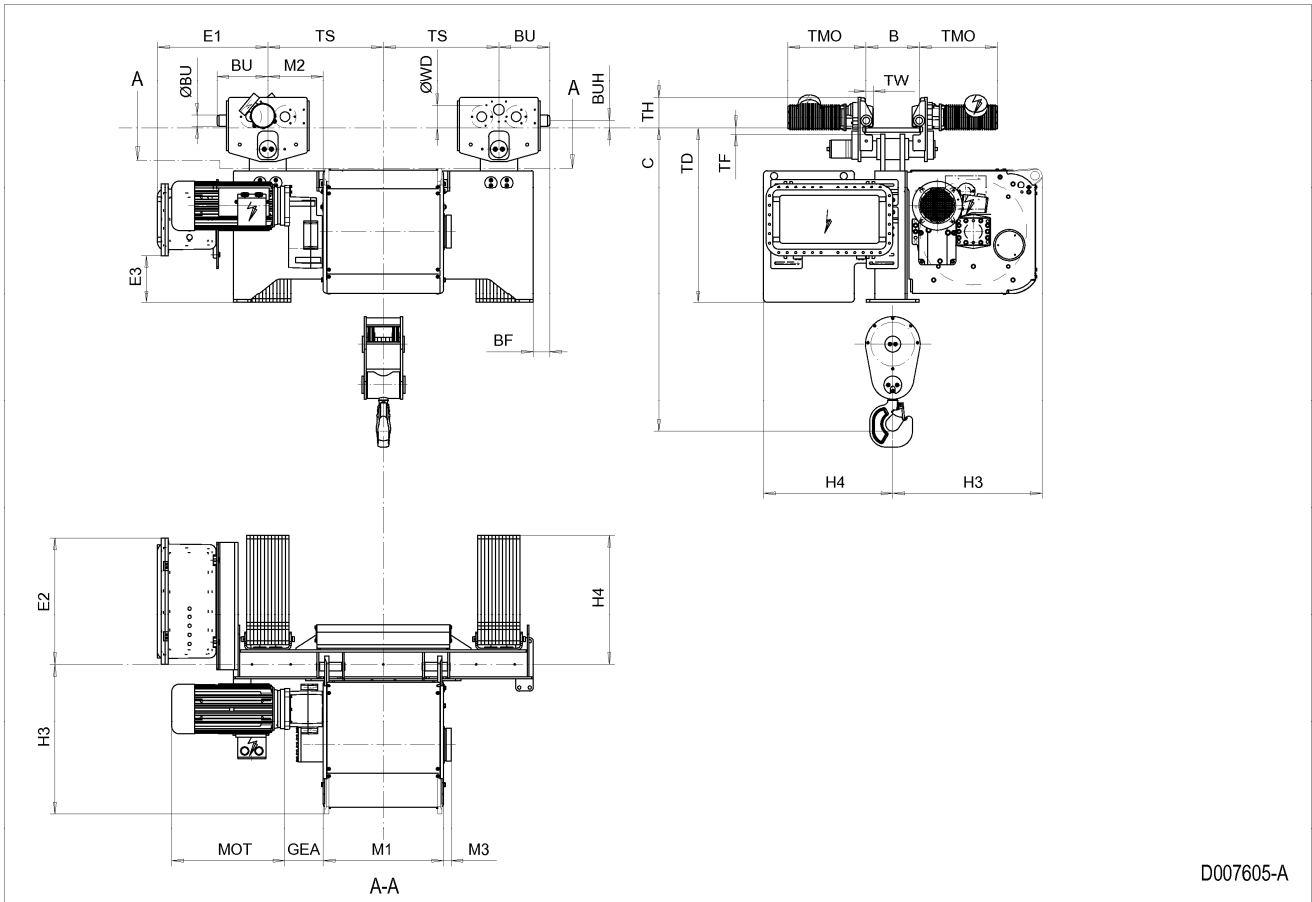

D007605-A

HOL	HOL*	Length code	E1	M1	M2	H3	H4	TS	BF	Weight**
m	m		mm	mm	mm	mm	mm	mm	mm	kg
15	8.5	E	741	682	314	847	732.5	655	93	2300
21	14.5	F	741	832	239	847	732.5	655	93	2400
28.5	22	G	741	1022	144	847	732.5	655	93	2500
38	31.5	H	741	1272	319	847	732.5	955	93	2700
51.5	45	J	741	1622	144	847	732.5	955	93	3000
63.5	57	K	1061	1922	-306	847	732.5	655	-227	3300
77	70.5	L	1061	2272	-481	847	732.5	655	-227	3500
87	80.5	M	1036	2522	-306	847	732.5	955	-202	3800
98.5	92	N	1036	2822	-456	847	732.5	955	-202	4100

*HOL with drum brake

**Presence of a drum brake increases weight by 80 kgs.

Motor dimensions

Motor	P6
MOT (mm)	536
Weight (kg)	86

Traveling dimensions

Motor	MF06LA
TMO (mm)	398
Weight (kg)	7.8

Trolley dimensions

B min	B max	C	ØWD	ØBU	BU	BUH	E1	E2	E3	GEA	M3
120	610	1667	125	63	288	40	626.6	717.1	269.1	218	44
TD	TF	TH	TW								
998	35	170	41.5								

D007605_A
252561

Note: Weight calculated with P6 and MF06LA motors when B=300 mm.

Note: All dimensions in mm.