

Fixed Hoist EXSX6, REEVING: 062; Class I, Division 2

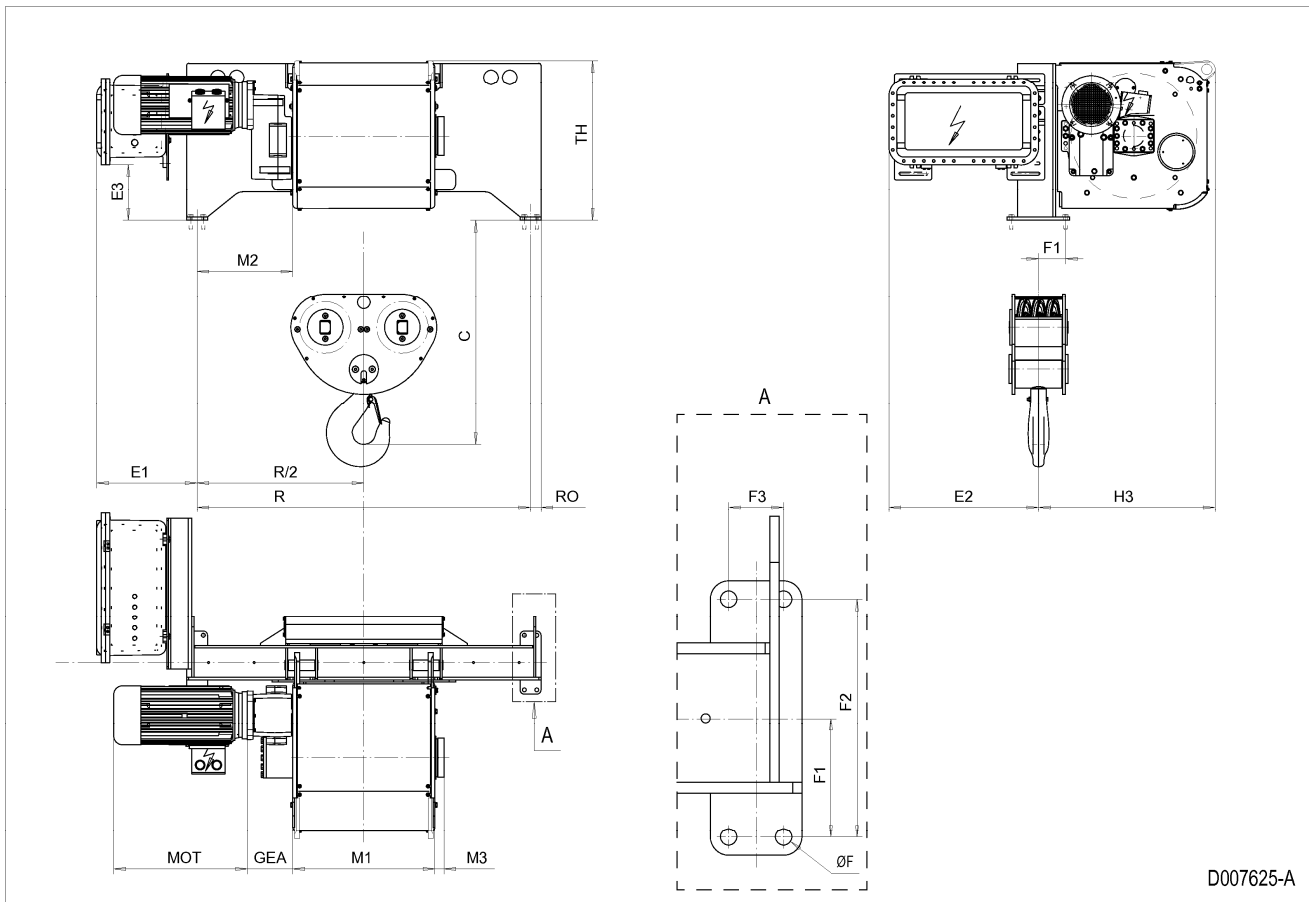

D007625-A

HOL m	HOL* m	Length code	R mm	M1 mm	M2 mm	Weight** kg
5	N/A	E	1600	682	459	1500
7	5	F	1600	832	384	1500
9.5	7.5	G	1600	1022	289	1600
12.5	10.5	H	2200	1272	464	1800
17	15	J	2200	1622	289	1900
21	19	K	2240	1922	164	2100
25.5	23.5	L	2240	2272	-10	2300
28.5	26.5	M	2790	2522	139	2400
32.5	30.5	N	2790	2822	-10	2600

*HOL with drum brake

**Presence of a drum brake increases weight by 80 kgs.

Motor dimensions

Motor	P6
MOT (mm)	536
Weight (kg)	86

Trolley dimensions

C	ØF	E1	E2	E3	F1	F2	F3	GEA	H3	M3	RO
1079	18	481.6	717.6	269.1	129.5	260	60	218	847	44	50
TH											
768											

D007625_A

252834

Note: Weight calculated with P6 motor.

Note: All dimensions in mm.