

Fixed Hoist EXSX6, REEVING: 062; Class I, Division 2

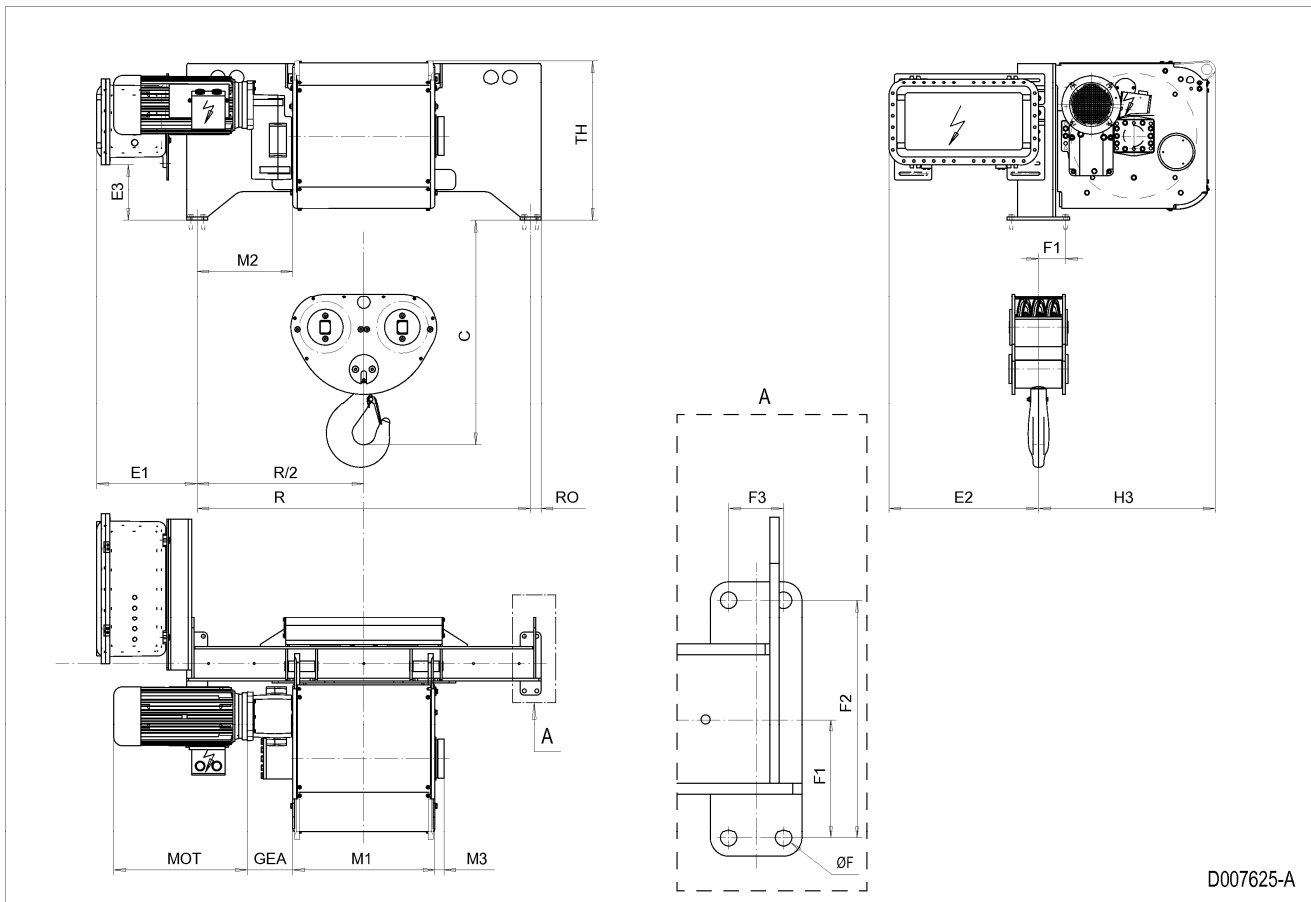

D007625-A

HOL ft	HOL* ft	Length code	R inch	M1 inch	M2 inch	Weight** lb
16'-5"	N/A	E	62.99	26.85	18.07	3308
22'-12"	16'-5"	F	62.99	32.76	15.12	3308
31'-2"	24'-7"	G	62.99	40.24	11.38	3528
41'-0"	34'-5"	H	86.61	50.08	18.27	3969
55'-9"	49'-3"	J	86.61	63.86	11.38	4190
68'-11"	62'-4"	K	88.19	75.67	6.46	4631
83'-8"	77'-1"	L	88.19	89.45	-0.39	5072
93'-6"	86'-11"	M	109.84	99.29	5.47	5292
106'-8"	100'-1"	N	109.84	111.1	-0.39	5733

\*HOL with drum brake

\*\*Presence of a drum brake increases weight by 176 lbs.

Motor dimensions

Motor	P6
MOT (inch)	21.1
Weight (lb)	190

Trolley dimensions

C	ØF	E1	E2	E3	F1	F2	F3	GEA	H3	M3	RO
42.48	0.71	18.96	28.25	10.59	5.1	10.24	2.36	8.58	33.35	1.73	1.97
TH											
30.24											

D007625\_A

252834

Note: Weight calculated with P6 motor.

Note: All dimensions in inch.