

Fixed Hoist EXSX6, REEVING: 082; Class I, Division 2

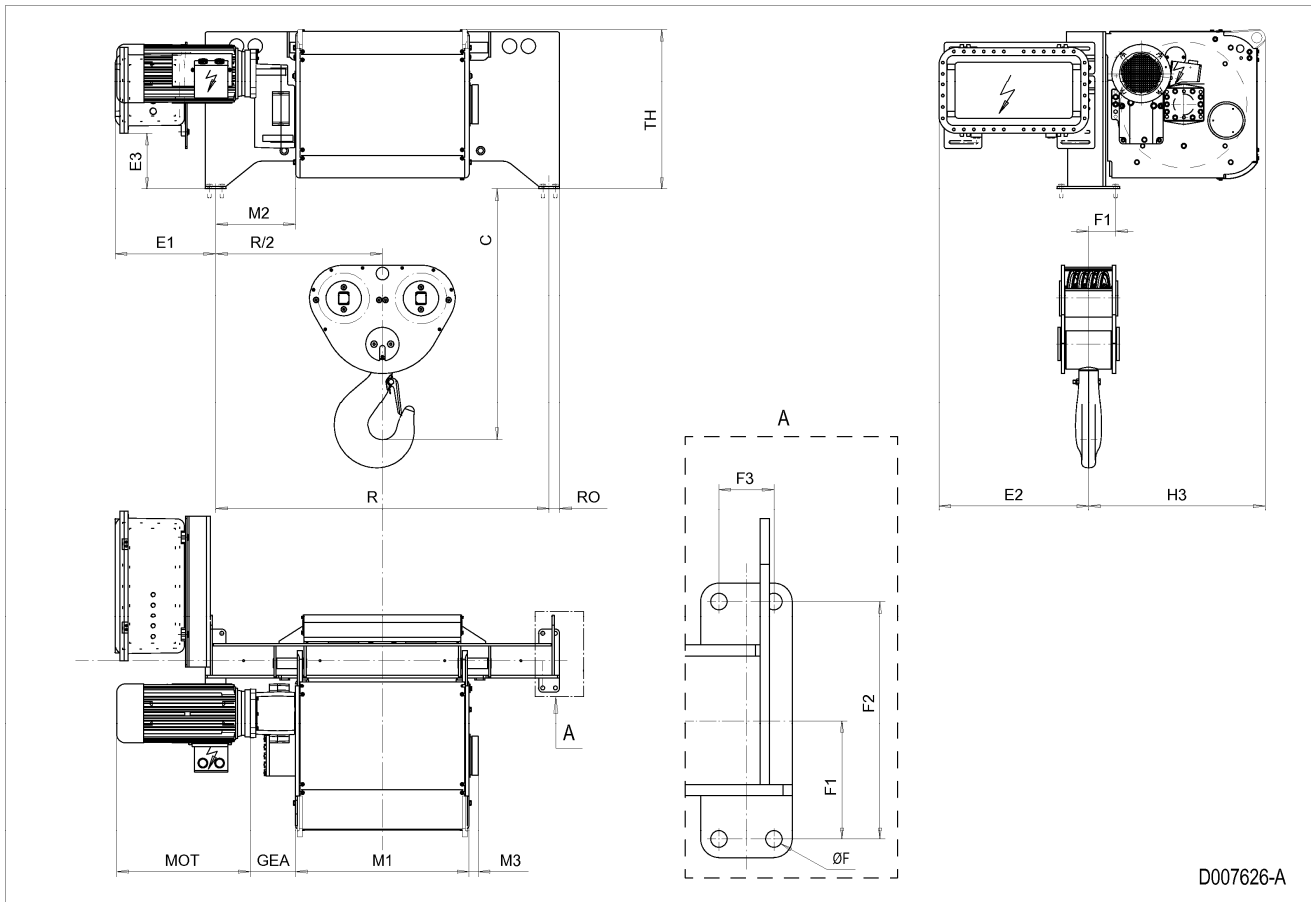

D007626-A

HOL m	HOL* m	Length code	R mm	M1 mm	M3 mm	Weight** kg
5	N/A	F	1600	832	384	1700
7	5.5	G	1600	1022	289	1700
9.5	8	H	2200	1272	464	1900
12.5	11	J	2200	1622	289	2100
15.5	14	K	2240	1922	164	2200
19	17.5	L	2240	2272	-10	2400
21.5	20	M	2790	2522	139	2600
24.5	23	N	2790	2822	-10	2700

*HOL with drum brake

**Presence of a drum brake increases weight by 80 kgs.

Motor dimensions

Motor	P6
MOT (mm)	536
Weight (kg)	86

Trolley dimensions

C	ØF	E1	E2	E3	F1	F2	F3	GEA	H3	M3	RO
1206	18	481.9	717.6	269.1	129.5	260	60	218	847	44	50
TH											
768											

D007626_A
252836

Note: Weight calculated with P6 motor.

Note: All dimensions in mm.