

# FOOT MOUNT, 4 PART DOUBLE

Hoist type:

SX7 042...F0

SI-60Hz

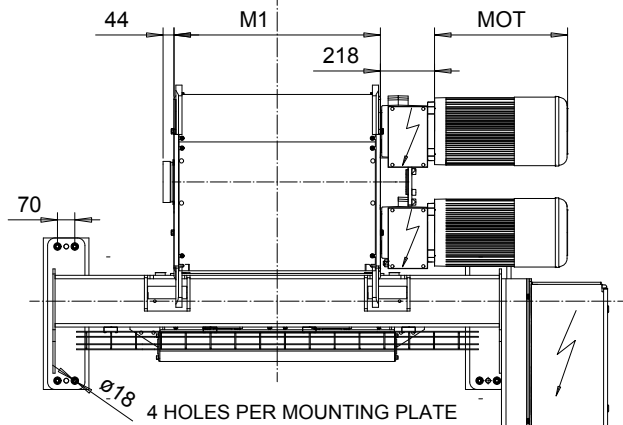
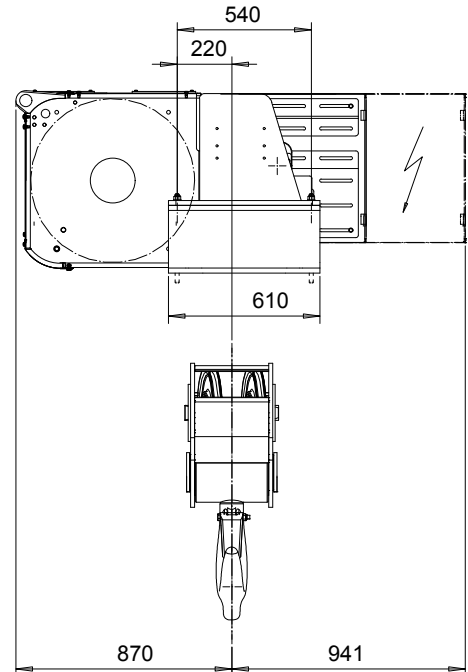
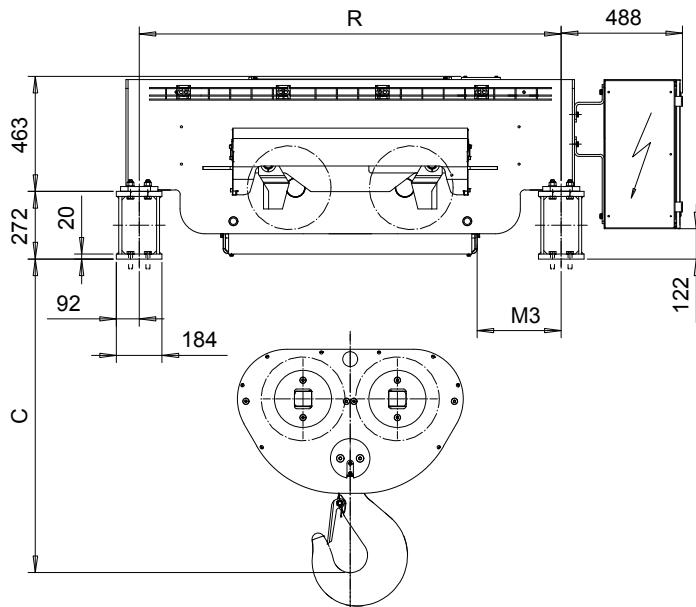

HOL	HOL*	Length code	R	M1	M3	Approx Weight
(m)	(m)		(mm)	(mm)	(mm)	(kg)
7.5	4	F	1700	832	434	1500
10	6.5	G	1700	1022	339	1500
13.5	10	H	2400	1272	565	1700
18.5	15	J	2400	1622	389	1800
23	19.5	K	3100	1922	339	2100
27.5	24	L	3100	2272	414	2200
31	27.5	M	3800	2522	840	2500
35.5	32	N	3800	2822	690	2600

HOL\* with optional drum brake Weight of drum brake is 80 kg.

Motor	P6	P7	P8	A7	S7	S8	SA
MOT (mm)	536	576	711	536	715	763	803
Weight (kg)	85	105	106	71	81	97	120

Load (kg)	Class Fem/ISO
25000	3m/M6
32000	2m/M5
40000	1Am/M4

Headroom - C dimension	
Standard	1263 mm
with HS22 Hook operated limit switch	1313 mm

Hoist weight calculated with P6 motor weight and without drum brake.

This document is the absolute property of R&M Materials Handling, Inc. This document must not be copied without the written permission of R&M Materials Handling, Inc. The contents thereof must not be disclosed to a third party nor be used for any unauthorized purpose. Contravention will be prosecuted.

ETTPAL Design	ETTPAL Chd	Appd	Ref Drawing	QE-F-24
2003-01-13 Date	HOIST; FIXED			
SLEODOCV Owner Dept	2X4 ROPE FALLS			
R&M MATERIALS HANDLING INC.	R&M MATERIALS HANDLING INC. HOIST & CRANE PRODUCTS SPRINGFIELD, OHIO	D006945-A		Issue 1/2018