

FOOT MOUNT, 8 PART DOUBLE

Hoist type:

SX7 082...F0

SI-60Hz

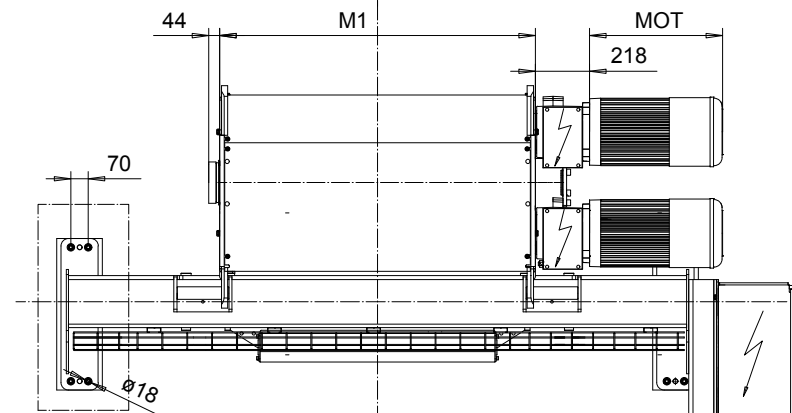
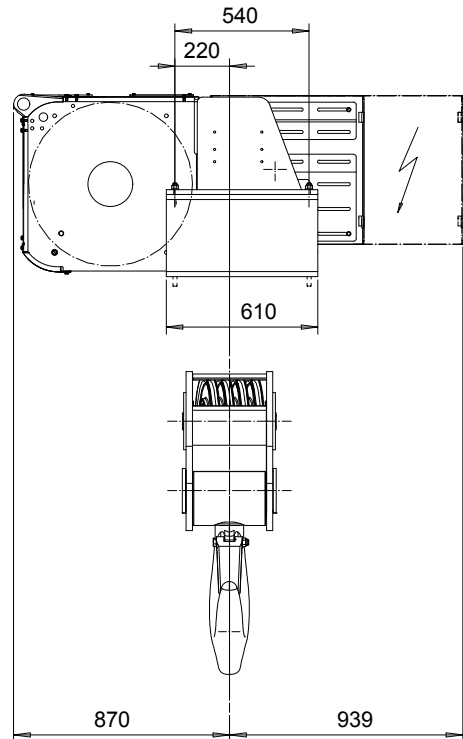
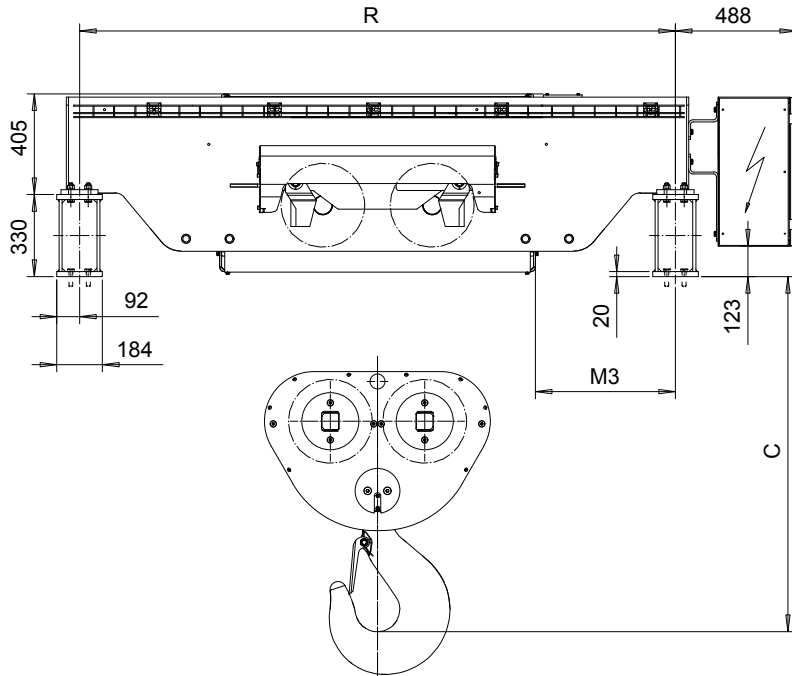

4 HOLES PER MOUNTING PLATE

HOL (m)	HOL* (m)	Length code	R (mm)	M1 (mm)	M3 (mm)	Approx Weight (kg)
6.5	4.5	H	2400	1272	565	2000
9	7	J	2400	1622	389	2200
11	9	K	3100	1922	339	2600
13.5	11.5	L	3100	2272	414	2700
15.5	13.5	M	3800	2522	840	3100
17.5	15.5	N	3800	2822	690	3200

HOL* with optional drum brake Weight of drum brake is 80 kg.

Motor	P6	P7	P8	A7	S7	S8	SA
MOT (mm)	536	576	711	536	715	763	803
Weight (kg)	85	105	106	71	81	97	120

Load (kg)	Class Fem/ISO
60000	2m/M5
80000	1Am/M4

Headroom - C dimension	
Standard	1430 mm
with HS22 Hook operated limit switch	1480 mm

Hoist weight calculated with P6 motor weight and without drum brake.

This document is the absolute property of R&M Materials Handling, Inc. This document must not be copied without the written permission of R&M Materials Handling, Inc. The contents thereof must not be disclosed to a third party nor be used for any unauthorized purpose. Contravention will be prosecuted.

ETTPAL Design	ETTPAL Chd	Appd	Ref Drawing	QE-F-28
2003-01-13 Date	HOIST; FIXED			
SLEODOCV Owner Dept	2X8 ROPE FALLS			
R&M MATERIALS HANDLING INC.	R&M MATERIALS HANDLING INC. HOIST & CRANE PRODUCTS SPRINGFIELD, OHIO	D006947-A		1:13 Folder
D006947-A_3				Issue 1/2018