

Double Girder Hoist EXSX7, REEVING: 022; Class I, Division 2

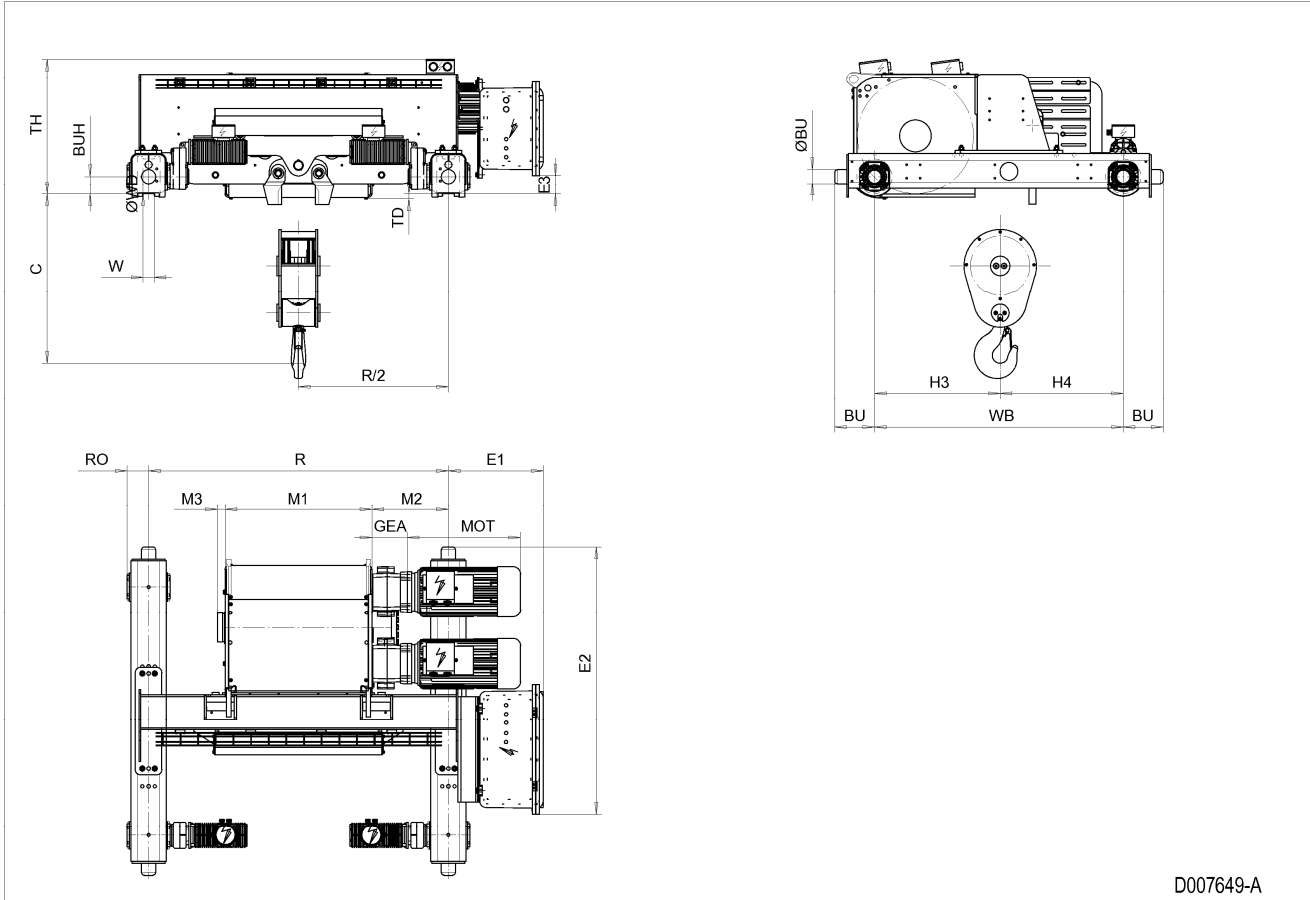

D007649-A

HOL m	HOL* m	Length code	M1 mm	M2 mm	Min R mm	Max R mm	Weight** kg
15.5	9	F	832	434	1700	2400	2060
20.5	14	G	1022	339	1700	2700	2210
27.5	21	H	1272	214	2000	3100	2340
37.5	31	J	1622	389	2400	3400	2530
46	39.5	K	1922	389	2700	3800	2690
55.5	49	L	2272	414	3100	4200	2880
62.5	56	M	2522	439	3400	4200	3040
71	64.5	N	2822	489	3800	4200	3230

\*HOL with drum brake

\*\*Presence of a drum brake increases weight by 80 kgs.

Motor Dimensions

Motor	P6
MOT (mm)	536
Weight (kg)	86

Traveling dimensions

Motor	MF06LA
Weight (kg)	7.8

Trolley Dimensions

C	ØWD	ØBU	BU	BUH	E1	E2	E3	GEA	H3	H4	M3
960	200	80	226	100	538.2	1514.8	105.7	201	712	698	44
RO	TD	TH	WB	W min	W max						
122	30	767	1410	54	99						

D004649\_A  
252894

Note: Weight calculated with P6 and MF06LA motors.

Note: All dimensions in mm.

Note: Standard rail gauges: 1700, 2000, 2400, 2700, 3100, 3400, 3800 and 4200.

Note: M2 and weight calculated with min R.

Note: Flangeless wheels available.