

Double Girder Hoist EXSX7, REEVING: 022; Class I, Division 2

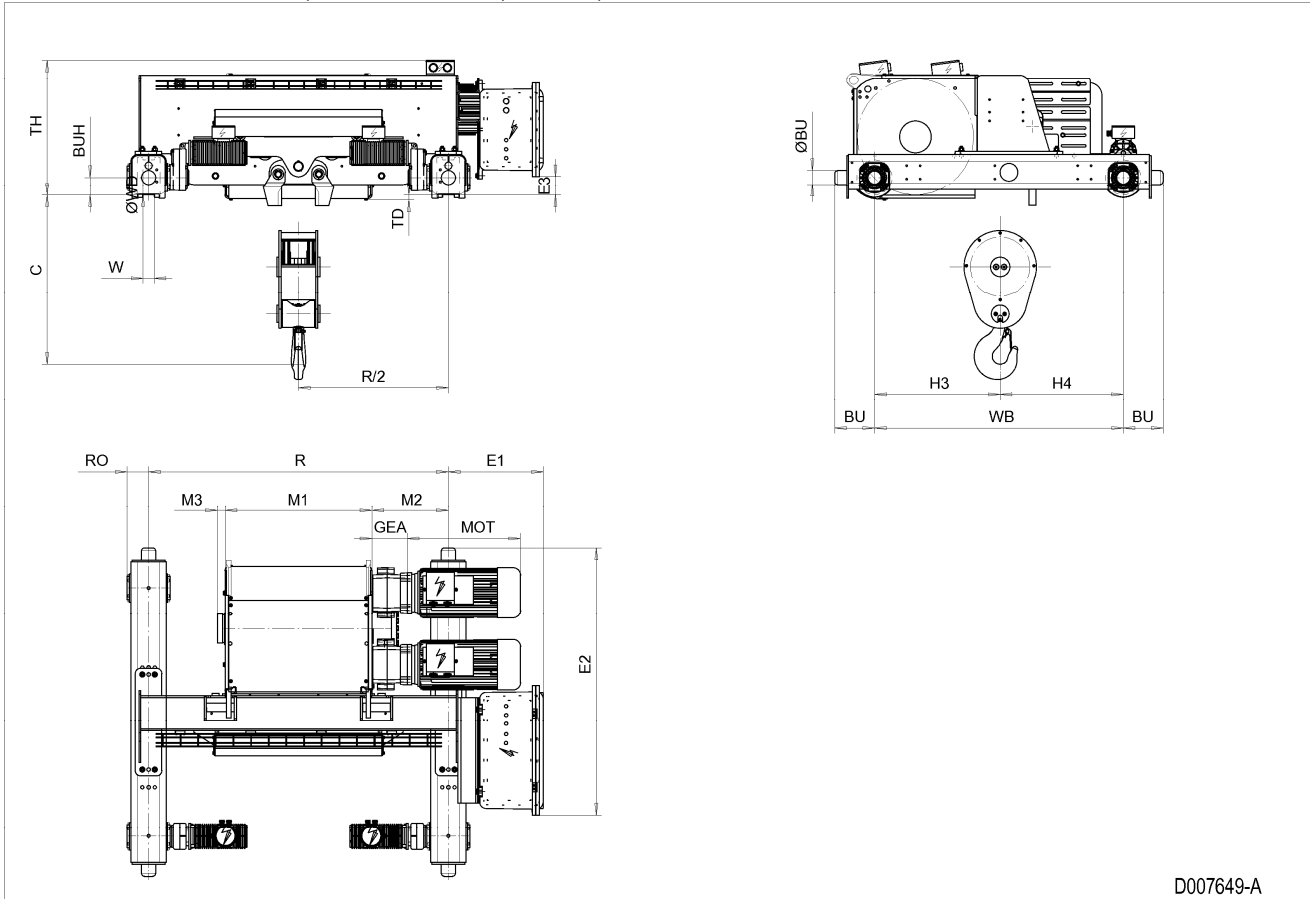

D007649-A

HOL ft	HOL* ft	Length code	M1 inch	M2 inch	Min R inch	Max R inch	Weight** lb
50'-10"	29'-6"	F	32.76	17.09	66.93	94.49	4542
67'-3"	45'-11"	G	40.24	13.35	66.93	106.3	4873
90'-3"	68'-11"	H	50.08	8.43	78.74	122.05	5160
123'-0"	101'-8"	J	63.86	15.31	94.49	133.86	5579
150'-11"	129'-7"	K	75.67	15.31	106.3	149.61	5931
182'-1"	160'-9"	L	89.45	16.3	122.05	165.35	6350
205'-1"	183'-9"	M	99.29	17.28	133.86	165.35	6703
232'-11"	211'-7"	N	111.1	19.25	149.61	165.35	7122

\*HOL with drum brake

\*\*Presence of a drum brake increases weight by 176 lbs.

Motor Dimensions

Motor	P6
MOT (inch)	21.1
Weight (lb)	190

Traveling dimensions

Motor	MF06LA
Weight (lb)	17

Trolley Dimensions

C	ØWD	ØBU	BU	BUH	E1	E2	E3	GEA	H3	H4	M3
37.8	7.87	3.15	8.9	3.94	21.19	59.64	4.16	7.91	28.03	27.48	1.73
RO	TD	TH	WB	W min	W max						
4.8	1.18	30.2	55.51	2.13	3.9						

D004649\_A

252894

Note: Weight calculated with P6 and MF06LA motors.

Note: All dimensions in inch.

Note: Standard rail gauges: 66.9, 78.7, 94.5, 106.3, 122, 133.9, 149.6 and 165.4.

Note: M2 and weight calculated with min R.

Note: Flangeless wheels available.