

Double Girder Hoist EXSX7, REEVING: 062; Class I, Division 2

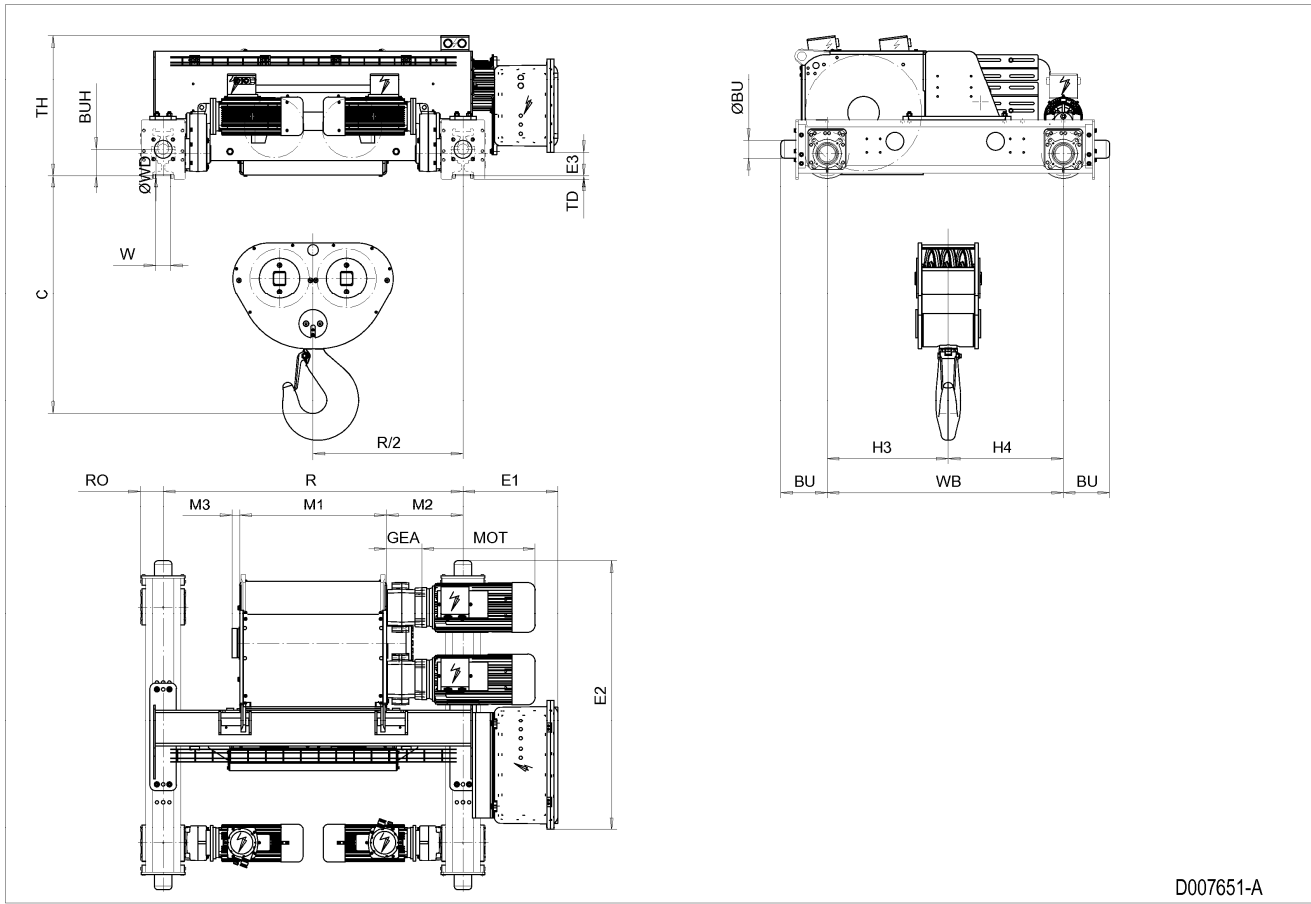

D007651-A

HOL ft	HOL* ft	Length code	M1 inch	M2 inch	Min R inch	Max R inch	Weight** lb
16'-5"	8'-2"	F	32.76	17.09	66.93	94.49	6395
21'-4"	13'-1"	G	40.24	13.35	66.93	106.3	6747
29'-6"	21'-4"	H	50.08	8.43	78.74	122.05	7056
41'-0"	32'-10"	J	63.86	15.31	94.49	133.86	7563
49'-3"	41'-0"	K	75.67	15.31	106.3	149.61	8114
60'-8"	52'-6"	L	89.45	16.3	122.05	165.35	8710
67'-3"	59'-1"	M	99.29	17.28	133.86	165.35	9173
77'-1"	68'-11"	N	111.1	19.25	149.61	165.35	9724

\*HOL with drum brake

\*\*Presence of a drum brake increases weight by 176 lbs.

Motor Dimensions

Motor	P6
MOT (inch)	21.1
Weight (lb)	190

Traveling dimensions

Motor	MF10M
Weight (lb)	57

Trolley Dimensions

C	ØWD	ØBU	BU	BUH	E1	E2	E3	GEA	H3	H4	M3
53.31	9.84	3.94	10.31	5.91	21.19	60.07	5.22	7.91	27.05	25.71	1.73
RO	TD	TH	WB	W min	W max						
5.08	0.79	31.26	52.76	2.13	3.9						

D007651\_A

252896

Note: Weight calculated with P6 and MF10M motors.

Note: All dimensions in inch.

Note: Standard rail gauges: 66.9, 78.7, 94.5, 106.3, 122, 133.9, 149.6 and 165.4.

Note: M2 and weight calculated with Min R.

Note: Flangeless wheels available.