

Fixed Hoist EXSX7, REEVING: 062; Class I, Division 2

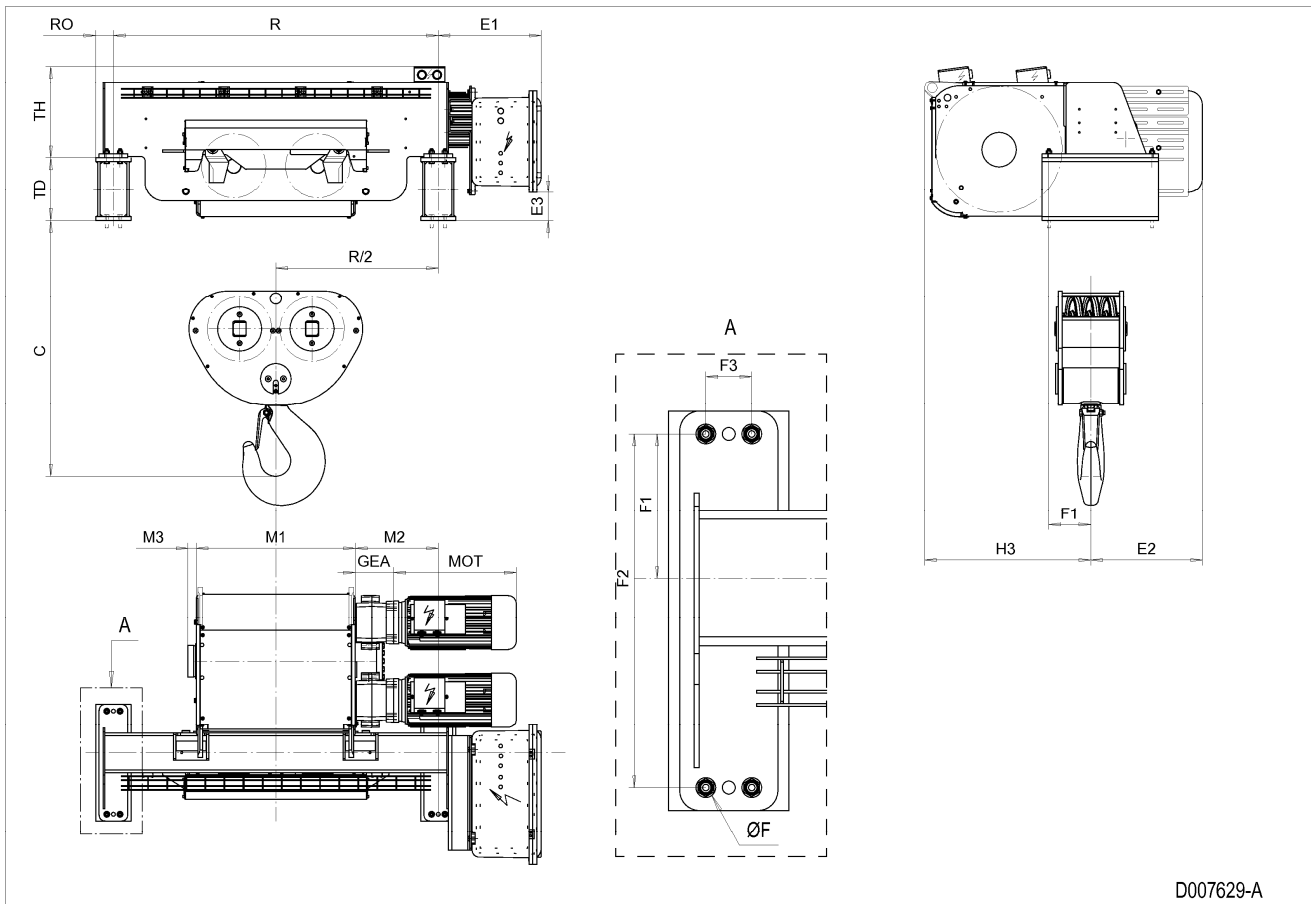

D007629-A

HOL m	HOL* m	Length code	R mm	M1 mm	M2 mm	Weight** kg
5	2.5	F	1700	832	434	1950
6.5	4	G	1700	1022	339	2050
9	6.5	H	2400	1272	565	2250
12.5	10	J	2400	1622	389	2350
15	12.5	K	3100	1922	339	2750
18.5	16	L	3100	2272	414	2950
20.5	18	M	3800	2522	840	3350
23.5	21	N	3800	2822	690	3450

*HOL with drum brake

**Presence of a drum brake increases weight by 80 kgs.

Motor dimensions

Motor	P6
MOT (mm)	536
Weight (kg)	86

Trolley dimensions

C	ØF	E1	E2	E3	F1	F2	F3	GEA	H3	M3	RO
1339	18	538.2	583.6	147.7	220	540	70	201	871	44	92
TD	TH										
330	479										

D007629_A

252839

Note: Weight calculated with P6 motor.

Note: All dimensions in mm.