

Fixed Hoist SXEX7, REEVING: 082; Class I, Division 2

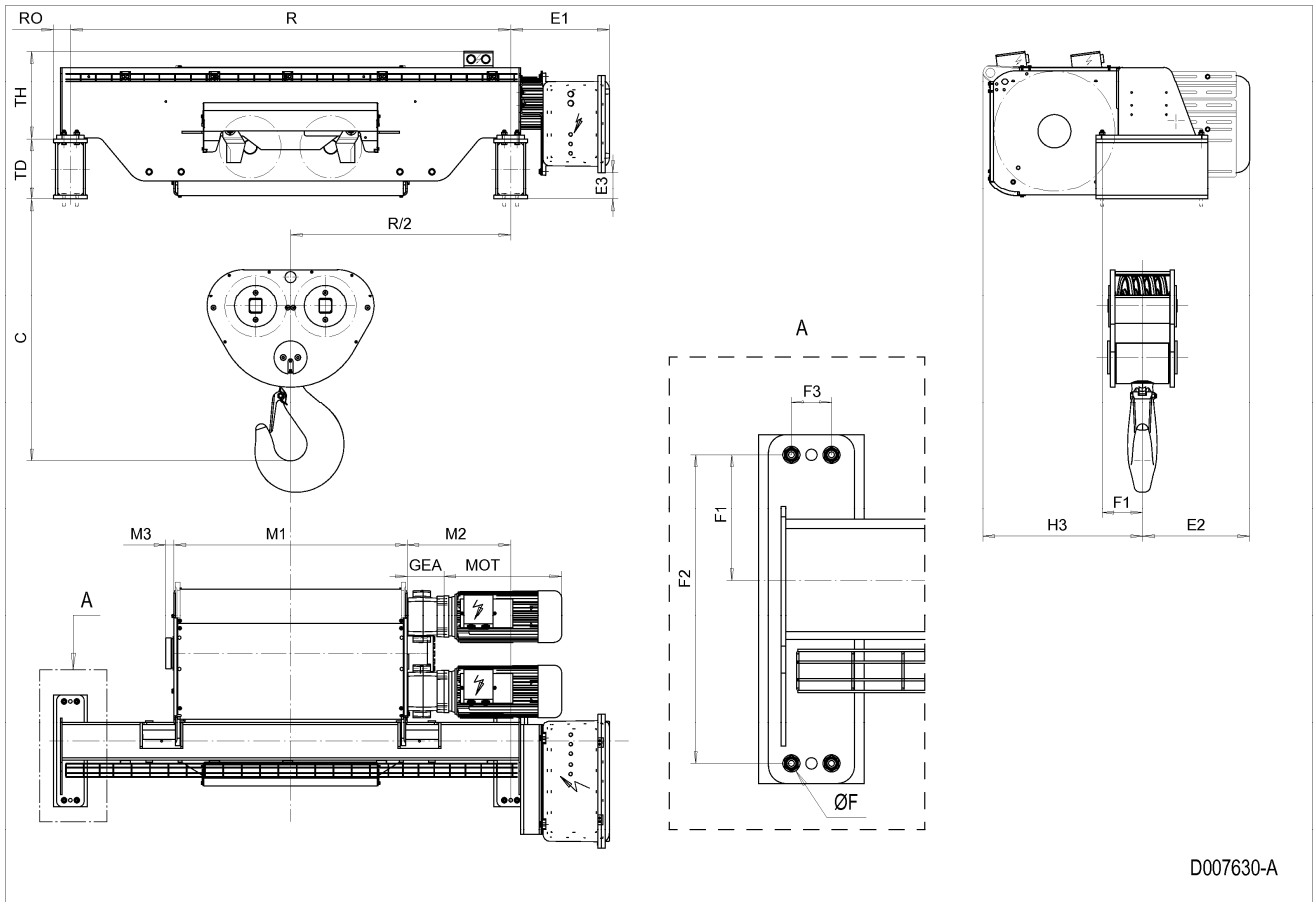

D007630-A

HOL ft	HOL* ft	Length code	R inch	M1 inch	M2 inch	Weight** lb
21'-4"	14'-9"	H	94.49	50.08	22.24	5182
29'-6"	22'-12"	J	94.49	63.86	15.31	5623
36'-1"	29'-6"	K	122.05	75.67	13.35	6505
44'-3"	37'-9"	L	122.05	89.45	16.3	6725
50'-10"	44'-3"	M	149.61	99.29	33.07	7607
57'-5"	50'-10"	N	149.61	111.1	27.17	7828

*HOL with drum brake

**Presence of a drum brake increases weight by 176 lbs.

Motor dimensions

Motor	P6
MOT (inch)	21.1
Weight (lb)	190

Trolley dimensions

C	ØF	E1	E2	E3	F1	F2	F3	GEA	H3	M3	RO
56.3	0.71	21.19	22.98	5.81	8.66	21.26	2.76	7.91	34.29	1.73	3.62
TD	TH										
12.99	18.86										

D007630_A
252841

Note: Weight calculated with P6 motor.

Note: All dimensions in inch.