

**LOW HEADROOM, 2 PART SINGLE (A2), SPECIAL**  
**Hoist type:**  
**SX4 021 (A2)...L0**

SI-50Hz

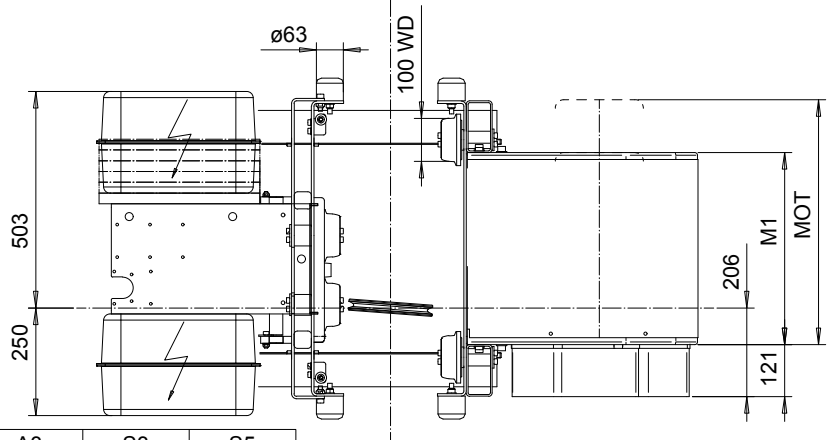
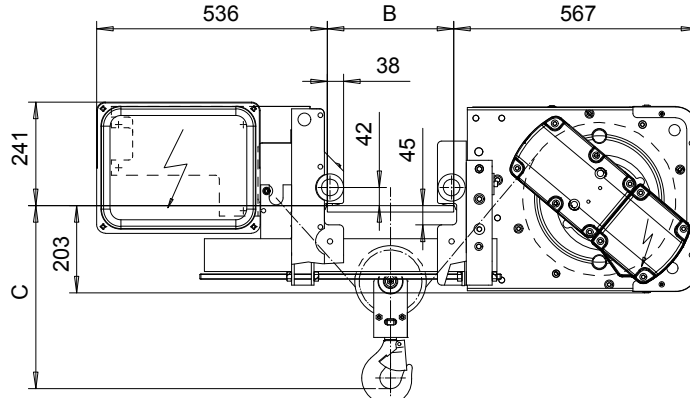
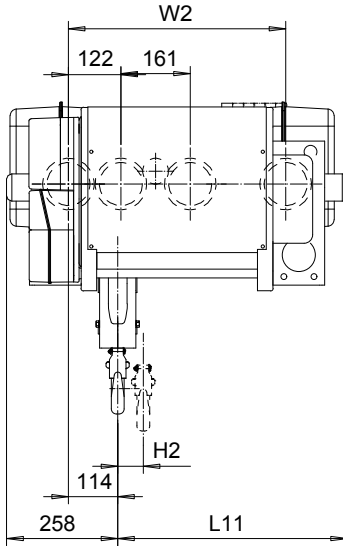

Motor	P2	P4	A3	S3	S5
MOT (mm)	446	574	446	526	602
Weight (kg)	35	53	32	28	53

HEADROOM TABLE - C dimension		
Flange Width, B (mm)	Headroom, C (mm)	with HS22 Hook oper limit switch (mm)
100 - 250	450	615
251 - 300	450	615
301 - 350	475	615
351 - 400	505	615
401 - 450	540	615
451 - 490	570	615

Headroom is related to the flange width

HOL (m)	Length code	H2 (mm)	L11 (mm)	M1 (mm)	W2 (mm)	Approx Weight (kg)
22.5	C	144	446	456	505	373
30	D	193	546	556	605	393

Load (kg)	Class Fem/ISO
1000	3m/M6
1250	3m/M6
1600	2m/M5

This document is the absolute property of R&M Materials Handling, Inc. This document must not be copied without the written permission of R&M Materials Handling, Inc. The contents thereof must not be disclosed to a third party nor be used for any unauthorized purpose. Contravention will be prosecuted.

CSDPAL Design	CSDPAL Chd	Appd	Ref Drawing	QB-L-A2
2002-08-28 Date	TROLLEY; LOW HEADROOM			1:7.5
SLEIENG1 Owner Dept	2 ROPE FALLS, 1600 kg			Folder
R&M MATERIALS HANDLING INC.	R&M MATERIALS HANDLING INC HOIST & CRANE PRODUCTS SPRINGFIELD, OHIO	D002106-A		Issue 6