

DOUBLE GIRDER, HIGH CLEARANCE, 6 PART DOUBLE
Hoist type:
SX5 062...DH

US-60Hz

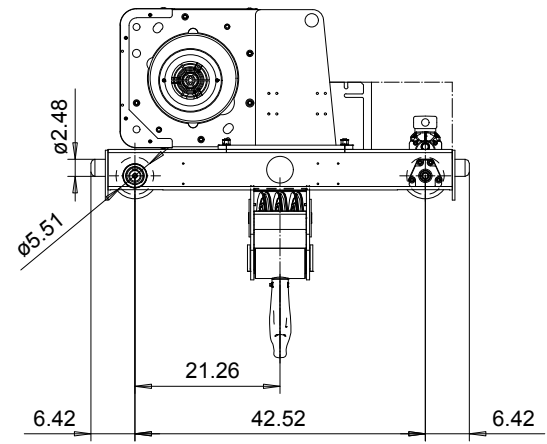
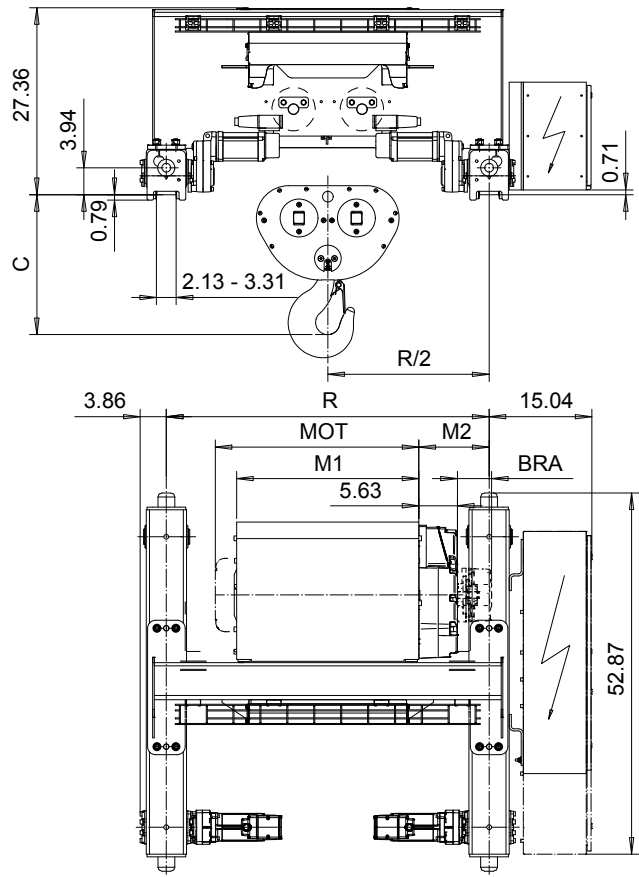

Motor	P5	P6	P7	A5	S5	S7
MOT (in)	22.76	22.76	24.33	19.61	23.86	29.8
Weight (lb)	128	187	231	99	117	179

HOL (ft)	Length code	M1 (inch)	M2 (inch)	BRA (inch)	Min R	Approx Weight (lb)
13'-1"	E	26.69	15.87	-	3'-11 1/4"	1742
19'-8"	F	32.6	20.31	-	4'-7 1/8"	1830
26'-2"	G	40.08	26.22	-	5'-6 7/8"	1951
36'-1"	H	49.93	8.5	5.63	5'-6 7/8"	2061
49'-2"	J	63.7	16.69	5.63	7'-10 1/2"	2315

Load (ton)	Class
12	H4+
15	H4

Headroom - C dimension	
Standard	20.5"
with HS22 Hook operated limit switch	22.5"

Note: Brake mounted to gearcase for Length code H & J
 Standard rail gauges are 3'-11 1/4", 4'-7 1/8", 5'-6 7/8", 6'-6 3/4", and 7'-10 1/2"
 Approx weight calculated with P5 motor and Min R
 M2 calculated with Min R.

This document is the absolute property of R&M Materials Handling, Inc. This document must not be copied without the written permission of R&M Materials Handling, Inc. The contents thereof must not be disclosed to a third party nor be used for any unauthorized purpose. Contravention will be prosecuted.

ETTPAL Design	ETTPAL Chd	Appd	Ref Drawing	QC-H-26
2002-06-29 Date	TROLLEY; DOUBLE GIRDER			1:12
SLEQDQCV Owner Dept	HIGH, 2x6 ROPE FALLS			Folder
R&M MATERIALS HANDLING INC.	R&M MATERIALS HANDLING, INC HOIST & CRANE PRODUCTS SPRINGFIELD, OHIO	D007184-A		Issue 2