

DOUBLE GIRDER, MEDIUM, 8 PART SINGLE

Hoist type:

SX6 081...D0

SI-60Hz

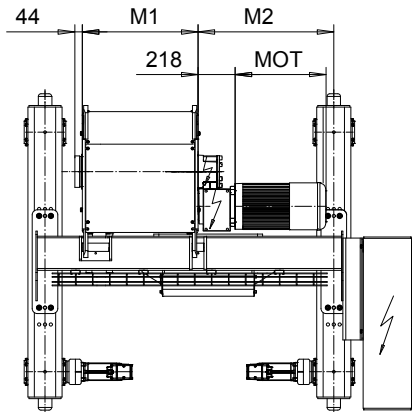
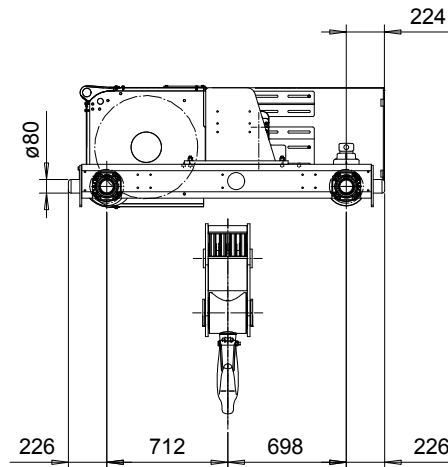
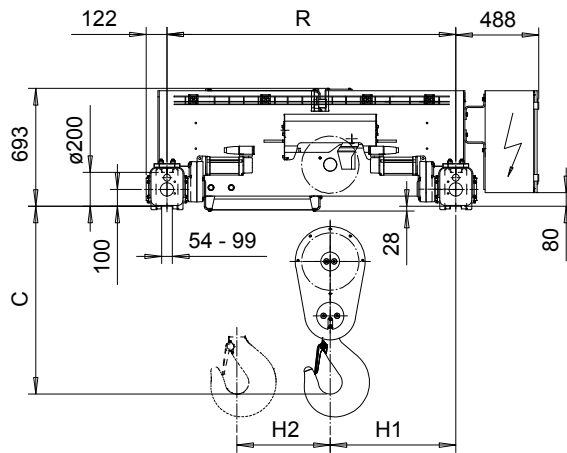

HOL	HOL*	Length	M1	M2	H1	H2	Min R	Max R	Approx Weight
(m)	(m)	code	(mm)	(mm)	(mm)	(mm)	(mm)	(mm)	(kg)
7	5.5	E	682	799	739	63	1700	3100	1780
9	7.5	F	832	949	889	81	2000	3100	1880
11.5	10	G	1022	1149	1089	105	2400	3100	2010
15	13.5	H	1272	1469	1409	137	3100	3800	2280
20	18.5	J	1622	1559	1499	180	3400	4200	2510
24	22.5	K	1922	1944	1884	217	4200	4200	2890

HOL* with optional drum brake Weight of drum brake is 80 kg.

Motor	P6	P7	P8	A7	S7	S8	SA
MOT (mm)	536	576	711	536	715	763	803
Weight (kg)	85	105	106	71	81	97	120

Load	Class
(kg)	Fem/ISO
32000	2m/M5
40000	1Am/M4

Headroom - C dimension	
Standard	1105 mm
with HS22 Hook operated limit switch	1155 mm

Standard rail gauges are 1700, 2000, 2400, 2700, 3100, 3400, 3800, and 4200 mm.

H1 and M2 are listed at Min R.

Hoist weight calculated at Min R, with P6 motor, without drum brake.

This document is the absolute property of R&M Materials Handling, Inc. This document must not be copied without the written permission of R&M Materials Handling, Inc. The contents thereof must not be disclosed to a third party nor be used for any unauthorized purpose. Contravention will be prosecuted.

ETTPAL Design	ETTPAL Chd	Appd	Ref Drawing	QD-M-08
2002-09-02 Date	TROLLEY; DOUBLE GIRDER			1:19
SLEODOCV Owner Dept	MEDIUM, 8 ROPE FALLS			Folder
R&M MATERIALS HANDLING INC.	R&M MATERIALS HANDLING, INC HOIST & CRANE PRODUCTS SPRINGFIELD, OHIO	D006650-A		Issue 6