

DOUBLE GIRDER, ADJUSTABLE LOAD BEAM, 4 PART SINGLE
 Hoist type:
 SX5 041...D0

SI-60Hz

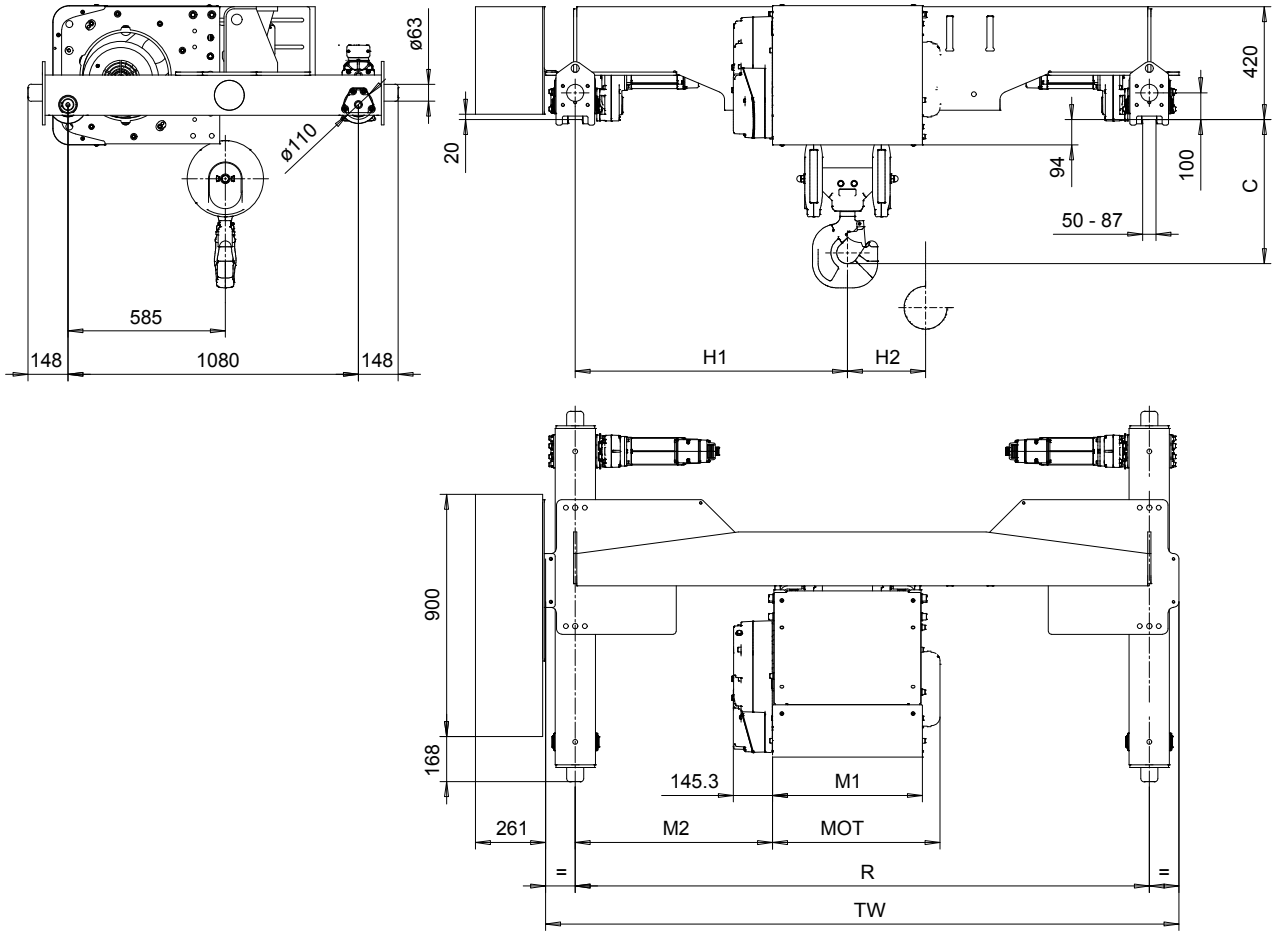

Load (kg)	Class Fem/ISO
5000	3m/M6
6300	3m/M6
8000	3m/M6
10000	2m/M5

Motor	P5	P6	P7	A5	S5	S7
MOT (mm)	578	578	618	498	606	757
Weight (kg)	58	85	105	45	53	81

HOL (m)	Length code	M1 (mm)	M2 (mm)	H1 (mm)	H2 (mm)	TW (mm)	Min R (mm)	Max R (mm)	Approx Weight (kg)
9	D	558	428	707	88	2354	1524	2134	670
12	E	678	428	707	118	2354	1524	2134	700
16	F	828	428	707	156	2354	1524	2134	745

Headroom - C dimension	
Standard	421 mm
with HS22 Hook operated limit switch	471 mm

Note: H1 and M2 are calculated from Min R.
 Special rail gauges from 1524 mm to 2134 mm
 Approx weight calculated with P5 motor

This document is the absolute property of R&M Materials Handling, Inc. This document must not be copied without the written permission of R&M Materials Handling, Inc. The contents thereof must not be disclosed to a third party nor be used for any unauthorized purpose. Contravention will be prosecuted.

ETTPAL Design	ETTPAL Chd	Appd	Ref Drawing	QC-ALB-04
2018-05-12 Date	TROLLEY; DOUBLE GIRDER			1:12
SLEQDQCV Owner Dept	ADJUSTABLE LOAD BEAM, 4 ROPE FALLS			Folder
R&M MATERIALS HANDLING INC.	R&M MATERIALS HANDLING, INC. HOIST & CRANE PRODUCTS SPRINGFIELD, OHIO	D53723434-vxp1-1		Issue 1